

The Electrical Constants of a Crustacean Nerve Fibre

A. L. Hodgkin and W. A. H. Rushton

Proc. R. Soc. Lond. B 1946 **133**, doi: 10.1098/rspb.1946.0024, published 3 December 1946

References

Article cited in:

<http://rspb.royalsocietypublishing.org/content/133/873/444#related-urls>

Email alerting service

Receive free email alerts when new articles cite this article - sign up in the box at the top right-hand corner of the article or click [here](#)

- Lea, D. E. 1946 *Actions of radiations on living cells*. Camb. Univ. Press.
 Lea, D. E. & Salaman, M. H. 1942 *Brit. J. Exp. Path.* **23**, 27.
 Lea, D. E. & Smith, K. M. 1942 *Parasitology*, **34**, 227.
 Lea, D. E., Smith, K. M., Holmes, B. & Markham, R. 1944 *Parasitology*, **36**, 110.
 Lind, S. C. 1928 *Chemical effects of alpha-particles and electrons*. New York: Chemical Catalog Co.
 Luria, S. E. & Exner, F. M. 1941 *Proc. Nat. Acad. Sci., Wash.*, **27**, 370.
 Markham, R., Smith, K. M. & Lea, D. E. 1942 *Parasitology*, **34**, 317.
 Muller, H. J. 1922 *Amer. Nat.* **56**, 32.
 Syverton, J. T., Berry, G. P. & Warren, S. L. 1941 *J. Exp. Med.* **74**, 223.
 Wollman, E., Holweck, F. & Luria, S. E. 1940 *Nature*, **145**, 935.
 Wollman, E. & Lacassagne, A. 1940 *Ann. Inst. Pasteur*, **64**, 5.

The electrical constants of a crustacean nerve fibre

BY A. L. HODGKIN AND W. A. H. RUSHTON

The Physiological Laboratory, Cambridge

(Communicated by E. D. Adrian, F.R.S.—Received 3 October 1945)

Theoretical equations are derived for the response of a nerve fibre to the sudden application of a weak current. The equations describe the behaviour of the nerve fibre in terms of the membrane resistance and capacity, the axoplasm resistance and the resistance of the external fluid. Expressions are given which allow these four constants to be calculated from experimental observations.

Axons from *Carcinus maenas* were used in preliminary experiments. Quantitative determinations were made on a new single-fibre preparation—the 75μ diameter axon from the walking leg of the lobster (*Homarus vulgaris*). Currents with a strength of one-third to one-half threshold were used in the quantitative determinations.

The behaviour of lobster axons agreed with theoretical predictions in the following respects: (a) the steady extrapolar potential declined exponentially with distance; (b) the voltage gradient midway between two distant electrodes was uniform; (c) the rise and fall of the extrapolar potential at different distances conformed to the correct theoretical curves.

The extrapolar potential disappeared when the axon was treated with a solution of chloroform, indicating that the surface membrane was destroyed by this treatment, and that the potential recorded was in fact derived from the membrane.

The ratio of the internal to external resistance per unit length was found to be about 0.7.

The absolute magnitude of the action potential at the surface membrane was estimated at about 110 mV.

The specific resistance of the axoplasm had an average value of 60Ω cm., which was roughly three times that of the surrounding sea water.

The calculated resistance of one square centimetre of membrane was found to vary from 600 to 7000Ω in thirteen experiments.

The membrane capacity was of the order of $1.3\mu\text{F cm.}^{-2}$.

No trace of inductive behaviour could be observed in the majority of the experiments. But three axons with low membrane resistances showed effects which could be attributed either to inductance or to a small local response. The absence of inductive behaviour in axons with high membrane resistance does not prove the absence of an inductive element. Currents with a strength several times greater than threshold often produced oscillating potentials at the cathode.

A local response was always observed when the strength of current approached threshold. The response had a striking inflected form if the current strength was near threshold and its duration less than the utilization time.

Indirect evidence indicates that the membrane resistance falls to a low value during activity.

Experiments with non-medullated nerve fibres have shown that a sub-threshold electric current produces two quite distinct effects (Hodgkin 1938; Pumphrey, Schmitt & Young 1940). Currents with a strength less than half-threshold produce a voltage which behaves as though it were due to the passive accumulation of charge at the nerve membrane. This voltage varies linearly with the applied current and is sometimes called an electrotonic potential. Currents with a strength greater than half-threshold evoke an additional wave of negativity which is non-linear and which behaves as though it were a subliminal response in the cathodic part of the nerve fibre. The present paper is concerned with an analysis of the first of these effects and contains only qualitative observations of the second. There are several reasons for believing in the importance of such an analysis. In the first place a physical understanding of the passive behaviour of nerve is essential to any theory of excitation. Thus a strength-duration curve cannot be explained until the time course of the voltage across the excitable membrane is known. Nor can the mechanism of excitation by the action potential be fully understood until there exists a thorough knowledge of the effect of applied currents on a single nerve fibre. A physical analysis is also interesting because it provides an insight into the structure of the surface membrane. Physical chemists are now able to prepare very thin films of lipoid material between two aqueous phases (Dean 1939), and it is clearly of the utmost importance to compare the electrical resistance and capacity of such films with those of the surface membrane in the living cell. The membrane resistance is also interesting from a more general point of view. Many biological processes depend upon the movement of ions through cell membranes, and the rate at which ions are transferred across a membrane should be related to its electrical resistance. Our results may, therefore, be of use to those who study the ionic movements that occur in the processes of growth, secretion and respiration. But perhaps the most important reason for making an analysis of the passive properties of a nerve fibre is that such an analysis must precede an understanding of the more complicated electrical changes which make up the nervous impulse itself.

Certain assumptions about the electrical structure of a nerve fibre must be made before any analysis can be started. The basic assumption of our work is that the structure of a non-medullated nerve fibre is similar to that of other cells which are known to have an interior of conducting protoplasm and a thin surface membrane with a high leakage resistance and a large capacity per unit area (Höber 1910; Fricke & Morse 1925; Cole 1937, etc.). If this general type of structure is granted, it follows that the passive behaviour of a new fibre must be governed by the equations of cable theory (Cremer 1899; Hermann 1905; Rushton 1934; Bogue & Rosenberg 1934; Cole & Curtis 1938, and others). The quantitative behaviour of the fibre should be determined by four electrical constants, viz.

- (1) The electrical resistance of the fluid outside the nerve fibre.
- (2) The electrical resistance of the axoplasm.
- (3) The electrical capacity of the surface membrane.
- (4) The electrical resistance of the surface membrane.

One other parameter, the membrane inductance, may have to be added (Cole 1941), but will not be considered in the initial stages of this paper. There already exists a considerable amount of information about the magnitude of three of these quantities. The external resistance can be calculated from the volume and conductivity of the fluid bathing the nerve fibre; the cell interior appears to have a resistivity two or three times as great as that of the external fluid and the surface membrane to have a capacity of about $1\mu\text{F}/\text{sq.cm}$. Very little is known about the membrane resistance and measurements have so far been confined to a few plant cells (Blinks 1937) and one animal cell, the giant nerve fibre of the squid (Cole & Hodgkin 1939; Cole 1940).^{*} The determination of the membrane resistance was therefore the first aim of our experiments and measurement of the remaining constants was originally regarded as of secondary importance. But it so happens that one constant cannot be determined without making measurements of at least two others. An attempt was therefore made to determine all four quantities simultaneously on a single fibre. Four sets of measurements had to be made since there were four unknowns to be evaluated, and after several trials we chose the following methods:

- (1) The extent of spread of potential in the extrapolar region.
- (2) The rate of rise of potential in the extrapolar region.
- (3) The ratio of the applied current to the voltage recorded between cathode or anode and a distant extrapolar point.
- (4) The voltage gradient in the region midway between two distant electrodes.

Axons with a diameter of 30μ from *Carcinus maenas* (Hodgkin 1938) were used initially. This work served to develop the experimental technique, but the extent of spread of potential was thought too small for accurate measurement. A search was therefore made for a fibre with a larger diameter and a suitable preparation was eventually found in the walking legs of the lobster (*Homarus vulgaris*). The meropodite of the walking legs contains a few fibres which have a diameter of 75μ and are robust enough to permit isolation without damage. This preparation was used in the majority of experiments. Electrical measurements were made by applying rectangular pulses of current and recording the potential response photographically. About fifteen sets of film were obtained in May and June of 1939, and a preliminary analysis was started during the following months. The work was then abandoned and the records and notes stored for six years. A final analysis was made in 1945 and forms the basis of this paper. A certain amount of biophysical work has proceeded during the interval, but no one seems to have repeated these particular experiments.

NOMENCLATURE

The passive spread of potential which occurs in nerve fibres is sometimes described by the term polarization potential and sometimes electrotonus or electrotonic potential. Both words are unfortunate. Electrotonus implies that the

^{*} An estimate of the plasma membrane resistance in the frog's egg has been made by Cole & Guttman (1942).

axon is in a state of enhanced physiological activity: polarization potential that the change of voltage is due to an alteration of ionic concentration in the vicinity of the membrane. Weak currents do not necessarily evoke an active or tonic response; nor is it at all certain that there is a significant polarization in the sense of Nernst (1908) or Warburg (1899). For it seems likely that the change of voltage with current is due to a frictional resistance opposing the motion of ions and not to changes in ionic concentration. We have therefore avoided the use of both terms so far as is possible and have used instead words such as membrane potential or extrapolar potential according to the context.

Wherever possible we have used the same symbols as Cole and his colleagues. λ has been employed as a space constant and should not be confused with the λ of Hill's theory of excitation (Hill 1936). The dual use of symbols is unfortunate but cannot be avoided, since both American and British writers have used λ as a space constant (e.g. Cole & Curtis 1938; Rushton 1934).

THEORETICAL SECTION

Assumptions

(1) The axon has a uniform cable-like structure with a conducting core, an external conducting path and a surface membrane with resistance and capacity.

(2) The axon is sufficiently thin and the membrane resistance sufficiently high for the flow of current in core and interstitial fluid to be strictly parallel. An alternative statement of this assumption is that at any given distance along the nerve the potential is constant throughout the core or throughout the external fluid.

(3) The axoplasm and external fluid behave as pure ohmic resistances.

(4) The membrane resistance is constant when the current density through the membrane is small.

(5) The membrane capacity behaves like a pure dielectric with no loss.

These are general assumptions which allow the differential equations for current or potential to be written. Each assumption is really an approximation, but we shall show later that no very serious errors are likely to result from their use. Certain experimental conditions must also be defined in order to allow the differential equations to be solved. These may be stated in the following way:

(1) The extrapolar and interpolar lengths are sufficiently long to be taken as infinite.

(2) The electrodes are sufficiently fine to be considered of zero breadth.

(3) A current of rectangular wave form is passed through the nerve.

Symbols and definitions

Variables

x is distance along axon in cm.

t is time in seconds.

i_1 is the current in amperes flowing through the external fluid (figure 1).

i_2 is the current in amperes flowing through the axis cylinder.

I is the total current in amperes flowing through the fibre and external fluid
($I = i_1 + i_2$).

i_m is the current penetrating the surface membrane at any point in ampere cm.^{-1} .

V_1 is the potential in volts of the external fluid with respect to a distant point
($V_1 = -\int_{-\infty}^x r_1 i_1 dx$).

V_2 is the potential in volts of the axis cylinder with respect to a distant point
($V_2 = -\int_{-\infty}^x r_2 i_2 dx$).

V_m is the change in potential difference across the surface membrane which results from the flow of current ($V_m = V_1 - V_2$).

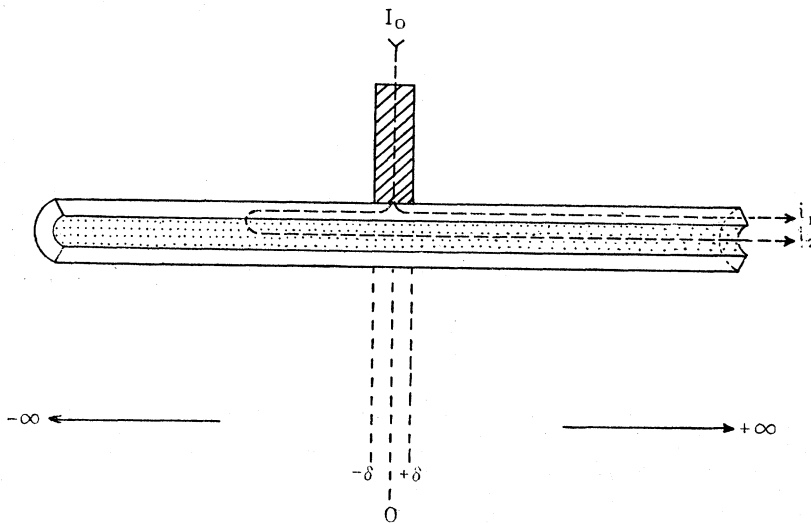

FIGURE 1. Geometry of system considered in theoretical section.

Basic constants

a is the radius of the axis cylinder in cm.

R_2 is the specific resistivity of the axoplasm in $\Omega \text{ cm.}$

R_4 is the resistance \times unit area of the surface membrane in $\Omega \text{ cm.}^2$.

C_M is the capacity per unit area of the surface membrane in F cm.^{-2} .

Practical constants

r_1 is the resistance per unit length of the external fluid in $\Omega \text{ cm.}^{-1}$.

r_2 is the resistance per unit length of the axis cylinder in $\Omega \text{ cm.}^{-1}$ ($r_2 = R_2/\pi a^2$).

r_4 is the resistance \times unit length of the surface membrane in the axon in $\Omega \text{ cm.}$
($r_4 = R_4/2\pi a$).

c is the capacity per unit length of the surface membrane in the axon in F cm.⁻¹
($c = C_M \times 2\pi a$).

$\lambda = \sqrt{(r_4/r_1 + r_2)}$, and is the characteristic length in cm.

$m = r_1 r_2 / (r_1 + r_2)$, and is the parallel resistance of the axis cylinder and external fluid in Ω cm.⁻¹.

$y = m\lambda r_1 / 2r_2 = r_1^2 \lambda / 2(r_1 + r_2)$.

$\tau_m = r_4 c = R_4 C_M$, and is the characteristic time of the surface membrane in seconds.

Miscellaneous

δ is equal to half the electrode width (figure 1). This quantity will eventually be made vanishingly small, but is introduced in order to deal with discontinuities. X , T , U , ξ and I_0 are best defined as they are introduced.

Theory

A number of useful equations follow at once from the definitions:

$$\frac{\partial V_1}{\partial x} = -r_1 i_1, \quad (1.0)$$

$$\frac{\partial V_2}{\partial x} = -r_2 i_2, \quad (1.1)$$

$$\frac{\partial V_m}{\partial x} = (r_1 + r_2) i_2 - I r_1, \quad (1.2)$$

$$V_m = \left(\frac{r_1 + r_2}{r_1} \right) V_1 + r_2 \int_{-\infty}^x I dx. \quad (1.3)$$

In the extrapolar region $I = 0$ so that (1.3) can be simplified to

$$V_m = \left(\frac{r_1 + r_2}{r_1} \right) V_1. \quad (1.4)$$

The total current through the membrane can be obtained in two ways:

$$i_m = \frac{\partial i_2}{\partial x}, \quad (1.5)$$

$$i_m = \frac{V_m}{r_4} + c \frac{\partial V_m}{\partial t}. \quad (1.6)$$

Hence

$$\frac{V_m}{r_4} + c \frac{\partial V_m}{\partial t} = \frac{\partial i_2}{\partial x}, \quad (1.7)$$

and on substituting from (1.2)

$$\frac{V_m}{r_4} + c \frac{\partial V_m}{\partial t} = \frac{1}{r_1 + r_2} \frac{\partial^2 V_m}{\partial x^2} + \frac{r_1}{r_1 + r_2} \frac{\partial I}{\partial x}, \quad (2.0)$$

or

$$-\lambda^2 \frac{\partial^2 V_m}{\partial x^2} + \tau_m \frac{\partial V_m}{\partial t} + V_m = r_1 \lambda^2 \frac{\partial I}{\partial x}. \quad (2.1)$$

Now $\partial I/\partial x$ vanishes except at the electrode, since $I = 0$ for $-\infty < x < -\delta$ and $I = I_0$ for $\delta < x < \infty$. Hence the following equation (2.2) applies to the regions $-\infty < x < -\delta$, $\delta < x < \infty$:

$$-\lambda^2 \frac{\partial^2 V_m}{\partial x^2} + \tau_m \frac{\partial V_m}{\partial t} + V_m = 0. \quad (2.2)$$

This equation must now be solved for the particular case where I is a constant current I_0 starting abruptly at $t = 0$.

The boundary conditions are

$$V_m = 0 \text{ everywhere } -\infty < t < 0, \quad V_m = 0 \text{ always when } x = \pm \infty.$$

There are also two continuity conditions. First, V_m is always a continuous function of x , since a discontinuity in V_m would mean that an infinite current must flow through the nerve. Secondly, i_2 is also a continuous function of x since the current density through the membrane cannot be infinite when $t \neq 0$. Introduce new variables $X = x/\lambda$, $T = t/\tau_m$, $U = V_m e^T$. Equation (2.2) can now be written

$$-\frac{\partial^2 V_m}{\partial X^2} + \frac{\partial V_m}{\partial T} + V_m = 0, \quad (2.3)$$

or

$$-\frac{\partial^2 U}{\partial X^2} + \frac{\partial U}{\partial T} = 0. \quad (2.4)$$

The operator q^2 may be substituted directly for $\partial/\partial T$ since $U = 0$ when $T = 0$. Hence

$$\frac{\partial^2 U}{\partial X^2} = q^2 U. \quad (3.0)$$

The solutions of (3.0) are

$$U = A e^{qX} + B e^{-qX}, \quad \text{when } -\infty < X < -\delta/\lambda,$$

$$U = A_1 e^{qX} + B_1 e^{-qX}, \quad \text{when } \delta/\lambda < X < \infty.$$

But the second boundary condition indicates that $U \neq \infty$ when $X = +\infty$, so $B = 0 = A_1$.

From the first continuity condition it follows that $A = B_1$, since

$$U_{X=\delta/\lambda} = U_{X=-\delta/\lambda},$$

when δ/λ is made vanishingly small. Hence

$$U = A e^{qX} \quad \text{for } -\infty < X < -\delta/\lambda, \quad (3.1)$$

$$U = A e^{-qX} \quad \text{for } \delta/\lambda < X < \infty. \quad (3.2)$$

The value of A can be found by applying the continuity of i_2 to equation (1.2). For

$$\left(\frac{\partial V_m}{\partial x}\right)_{x=\delta} - \left(\frac{\partial V_m}{\partial x}\right)_{x=-\delta} = (r_1 + r_2) \{(i_2)_{x=\delta} - (i_2)_{x=-\delta}\} - r_1 (I_{x=\delta} - I_{x=-\delta}),$$

whence

$$\left(\frac{\partial U}{\partial X}\right)_{X=\delta/\lambda} - \left(\frac{\partial U}{\partial X}\right)_{X=-\delta/\lambda} = -r_1 I_0 \lambda e^T,$$

which in the operational form becomes $-r_1 \lambda I_0 \frac{q^2}{q^2-1}$. But from (3.1) and (3.2)

$$\left(\frac{\partial U}{\partial X}\right)_{X=\delta/\lambda} - \left(\frac{\partial U}{\partial X}\right)_{X=-\delta/\lambda} = -2qA.$$

So
$$U = \frac{r_1 \lambda I_0}{4} \left\{ \frac{1}{q-1} + \frac{1}{q+1} \right\} e^{aX} \quad \text{for } -\infty < X < -\delta/\lambda, \quad (3.3)$$

and
$$U = \frac{r_1 \lambda I_0}{4} \left\{ \frac{1}{q-1} + \frac{1}{q+1} \right\} e^{-aX} \quad \text{for } \delta/\lambda < X < \infty. \quad (3.4)$$

The interpretations of the operational expressions in (3.3) and (3.4) are known (Jeffreys 1931). When they are substituted, the following equations for V_m are obtained:

$$V_m = \frac{r_1 \lambda I_0}{4} \{ e^X [1 + \operatorname{erf}(X/2\sqrt{T} + \sqrt{T})] - e^{-X} [1 + \operatorname{erf}(X/2\sqrt{T} - \sqrt{T})] \},$$

when $-\infty < X < 0$, (4.0)

and
$$V_m = \frac{r_1 \lambda I_0}{4} \{ e^{-X} [1 - \operatorname{erf}(X/2\sqrt{T} - \sqrt{T})] - e^X [1 - \operatorname{erf}(X/2\sqrt{T} + \sqrt{T})] \},$$

when $0 < X < \infty$, (4.1)

where
$$\operatorname{erf} Z = \frac{2}{\sqrt{\pi}} \int_0^Z e^{-\omega^2} d\omega.$$

These expressions satisfy equation (2.3) and the boundary conditions. Campbell & Foster (1931, p. 162) give an expression which is equivalent to (4.1) for the response of a non-inductive cable to the sudden application of current.

The solutions for the case when the applied current is maintained for a long time and then broken suddenly at $t = 0$ can be written down at once from the superposition theorem. They are

$$V_m = \frac{r_1 \lambda I_0}{4} \{ e^X [1 - \operatorname{erf}(X/2\sqrt{T} + \sqrt{T})] + e^{-X} [1 + \operatorname{erf}(X/2\sqrt{T} - \sqrt{T})] \},$$

when $-\infty < X < 0$, (4.2)

and
$$V_m = \frac{r_1 \lambda I_0}{4} \{ e^{-X} [1 + \operatorname{erf}(X/2\sqrt{T} - \sqrt{T})] + e^X [1 - \operatorname{erf}(X/2\sqrt{T} + \sqrt{T})] \},$$

when $0 < X < \infty$. (4.3)

Equations (4.0), (4.1) and (4.2), (4.3) are symmetrical pairs differing only in the sign of X . Thus it is necessary to compute only one set of curves in order to describe the distribution of potential for the make or break of a constant current. And the curves for the break of current can be obtained from those for the make by a direct application of the superposition theorem. Equation (4.1) is the most convenient to compute, since it deals with positive values of X . An evaluation of the essential part of (4.1) is given in table 1 and the results are plotted graphically in figure 2.

TABLE 1. TABLE OF THE FUNCTION $\{e^{-X}[1 - \operatorname{erf}(X/2\sqrt{T})] - e^X[1 - \operatorname{erf}(X/2\sqrt{T + \sqrt{T}})]\}$
FOR DIFFERENT VALUES OF X AND T

X	$T=0.01$	0.04	0.16	0.36	0.64	1.0	1.44	1.96	2.56	3.24	4.00	6.25	∞
0	0.2249	0.4454	0.8567	1.208	1.484	1.685	1.821	1.904	1.953	1.987	1.991	1.999	2.000
0.1	0.0795	0.2743	0.673	1.020	1.294	1.496	1.631	1.714	1.763	1.788	1.801	1.800	1.810
0.2	0.0200	0.1561	0.5201	0.855	1.126	1.325	1.459	1.542	1.590	1.616	1.628	1.636	1.637
0.3	0.0035	0.0816	0.3926	0.712	0.976	1.172	1.305	1.387	1.435	1.460	1.473	1.481	1.482
0.4	0.0004	0.0390	0.2921	0.588	0.842	1.034	1.165	1.247	1.294	1.320	1.332	1.340	1.341
0.5	—	0.0170	0.2125	0.483	0.725	0.911	1.040	1.120	1.167	1.192	1.204	1.212	1.213
0.6	—	0.0067	0.1513	0.392	0.621	0.801	0.926	1.006	1.052	1.077	1.089	1.097	1.098
0.7	—	0.0024	0.1055	0.316	0.530	0.702	0.824	0.903	0.948	0.972	0.984	0.992	0.993
0.8	—	0.00076	0.0718	0.252	0.450	0.614	0.732	0.809	0.853	0.878	0.890	0.898	0.899
0.9	—	—	0.0474	0.2000	0.381	0.537	0.651	0.725	0.769	0.793	0.804	0.812	0.813
1.0	—	—	0.0311	0.1554	0.319	0.467	0.577	0.649	0.691	0.715	0.727	0.735	0.736
1.2	—	—	0.0122	0.0937	0.224	0.351	0.451	0.517	0.560	0.583	0.594	0.601	0.602
1.5	—	—	0.0026	0.0401	0.125	0.225	0.309	0.369	0.407	0.428	0.438	0.445	0.446
2.0	—	—	0.0001	0.0086	0.0435	0.1008	0.159	0.205	0.236	0.254	0.263	0.270	0.271
2.5	—	—	—	0.0012	0.0129	0.0415	0.0773	0.1113	0.1347	0.1494	0.1574	0.1636	0.1642
3.0	—	—	—	—	0.0033	0.0174	0.0364	0.0581	0.0754	0.0870	0.0937	0.0988	0.0996

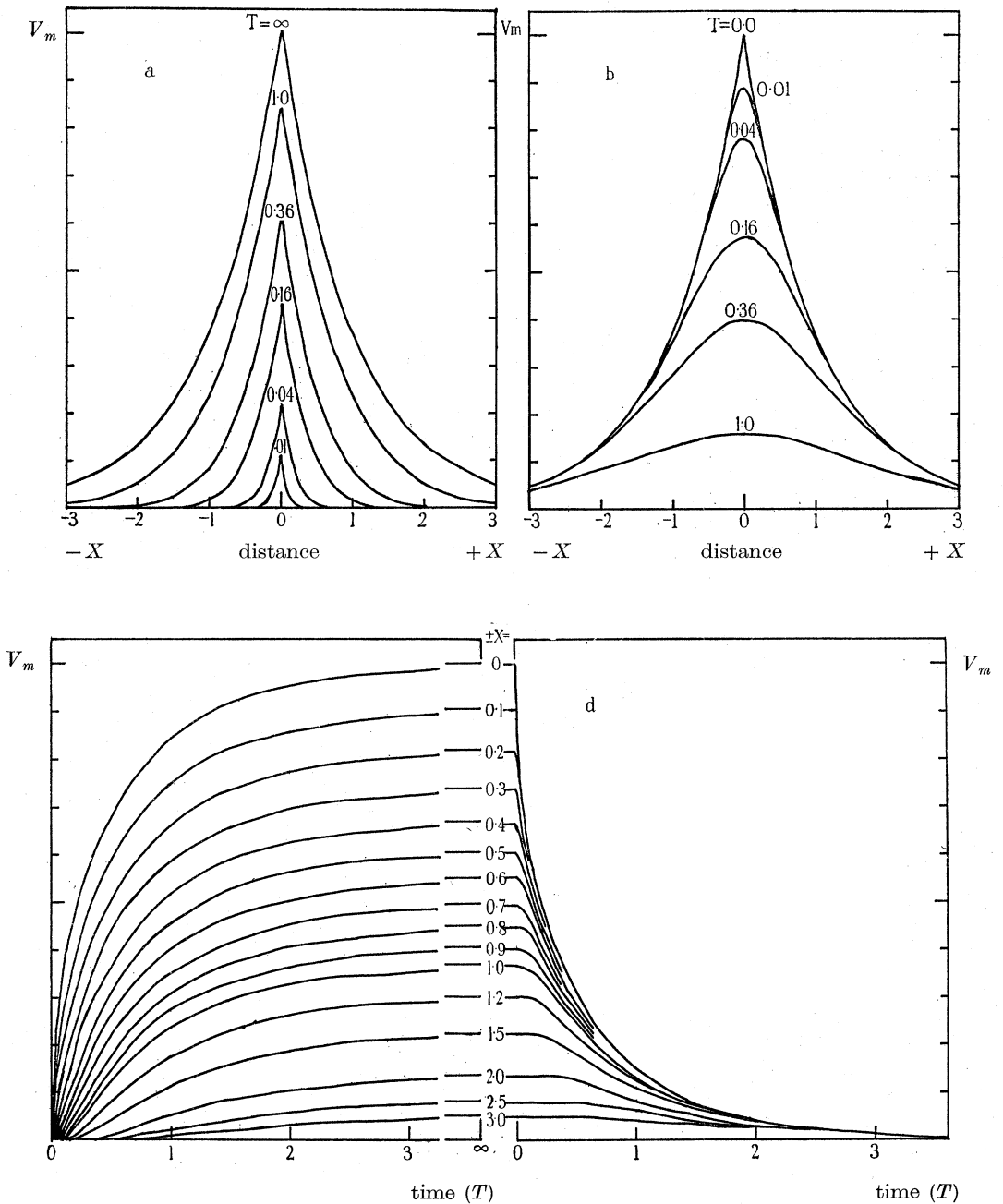

FIGURE 2. Theoretical behaviour of potential difference across nerve membrane (V_m). *a, b*, spatial distribution of potential at different times; *c, d*, time course of potential at different distances from electrode; *a, c*, current made at $T=0$; *b, d*, current maintained for a long time and then broken at $T=0$.

A great simplification of the mathematical theory can be achieved by considering the total charge in the region of the electrode instead of the membrane potential. Define total charge by a new variable

$$\xi = c \int_{-\infty}^{\beta} V_m dx, \quad (5.0)$$

where β is sufficiently large to allow the integration to include all the charge in the electrode region. β can be considered as infinite provided that the integration does not include the region of the second electrode. Integration of equation (2.1) from $-\infty$ to β gives

$$\tau_m \frac{\partial \xi}{\partial t} + \xi = r_1 c \lambda^2 I_0, \quad (5.1)$$

since

$$\int_{-\infty}^{\beta} \partial V_m / \partial t dx = \frac{\partial}{\partial t} \left[\int_{-\infty}^{\beta} V_m dx \right]$$

and $\frac{\partial V_m}{\partial x} = 0$ when $x = -\infty$ and $x = +\beta$. The solutions of (5.1) are

$$\xi = r_1 c \lambda^2 I_0 (1 - e^{-t/\tau_m}) \quad (5.2)$$

for a constant current made at $t = 0$ and

$$\xi = r_1 c \lambda^2 I_0 e^{-t/\tau_m} \quad (5.3)$$

for a constant current broken at $t = 0$. Unfortunately, these simple equations are of little practical use, since ξ can only be obtained indirectly from the experimental results.

The extrapolar potential

Equations (4.0) and (4.2) can be applied directly to the experimental results

since $V_m = \frac{r_1 + r_2}{r_1} V_1$, $X = x/\lambda$ and $T = t/\tau_m$.

The most convenient expressions for the make of current are

$$V_1 = (V_1)_{t=\infty} \frac{1}{2} \{ e^X [1 + \operatorname{erf}(X/2\sqrt{T} + \sqrt{T})] - e^{-X} [1 + \operatorname{erf}(X/2\sqrt{T} - \sqrt{T})] \}, \quad (6.0)$$

where

$$(V_1)_{t=\infty} = \frac{r_1^2 \lambda I_0}{2(r_1 + r_2)} = y I_0, \quad (6.1)$$

y being thus defined in the table of practical constants,

$$(V_1)_{t=\infty} = (V_1)_{t=\infty} e^X, \quad (6.2)$$

and

$$(V_1)_{x=0} = (V_1)_{t=\infty} \operatorname{erf}(\sqrt{T}). \quad (6.3)$$

For the break of current the relevant expressions are

$$V_1 = (V_1)_{t=0} \frac{1}{2} \{ e^X [1 - \operatorname{erf}(X/2\sqrt{T} + \sqrt{T})] + e^{-X} [1 + \operatorname{erf}(X/2\sqrt{T} - \sqrt{T})] \}, \quad (6.4)$$

and

$$(V_1)_{x=0} = (V_1)_{t=0} [1 - \operatorname{erf}(\sqrt{T})]. \quad (6.5)$$

The mid-interpolar gradient

The expressions given in the preceding paragraph allow λ , τ_m and y to be determined from experimental observations of the extrapolar potential. The constant m can be obtained from a measurement of the voltage gradient in the interpolar region at a large distance from either electrode. For equation (4.1) shows that

$$\left(\frac{\partial V_m}{\partial x}\right)_{x=\beta} = 0 \text{ when } \beta \gg \lambda. \text{ Hence differentiation of (1.3) gives}$$

$$-\left(\frac{\partial V_1}{\partial x}\right)_{x=\beta} / I_0 = \frac{r_1 r_2}{r_1 + r_2} = m. \quad (7.0)$$

Determination of basic constants

Convenient expressions for determining the basic constants are

$$R_2 = \pi a^2 m (1 + m\lambda/2y), \quad (8.0)$$

$$R_4 = 2\pi a \lambda^2 m (2 + m\lambda/2y + 2y/m\lambda), \quad (8.1)$$

$$C_M = \tau_m / R_4. \quad (8.2)$$

An expression for the resistivity of the external fluid is not given because there was no easy way of determining the volume of fluid surrounding the nerve fibre. Nor would this quantity have been of great interest. But it is desirable to have an index of the amount of short-circuiting introduced by the external fluid and the ratio r_2/r_1 has been used for this purpose. It can be computed by the relation

$$r_2/r_1 = m\lambda/2y. \quad (8.3)$$

VALIDITY OF ASSUMPTIONS

We are now in a better position to assess the errors which are introduced by the approximations made in the theory. The assumption of parallel current flow is not likely to involve any serious error provided that the current spreads over a length which is several times greater than the diameter of the axon. This condition was satisfied experimentally, since the average value for the space constant λ was twenty times greater than the axon diameter. The assumption of zero breadth for the electrode can be justified in the same way, since λ/δ was also of the order of twenty. Both approximations are doubtful at short time intervals. Thus figure 2 shows that the effective space constant is only $\lambda/5$ when t/τ_m is 0.04. But it can be said that the cable equations apply with reasonable accuracy provided $t/\tau_m > 0.04$.

In practice anode and cathode were separated by about 8 mm. of nerve; theory assumes them to be an infinite distance apart. But interference between the two electrode regions must have been negligible, since 8 mm. was equivalent to 5λ in an average experiment and e^{-5} is 0.007. A similar argument applies to the recording electrodes which were also 8 mm. apart.

The assumption that the internal and external resistances obey Ohm's law is fully justified by earlier work (see, for instance, Cole & Hodgkin 1939) and finds

further confirmation in the measurements of mid-interpolar gradient which will be described presently. The constancy of the membrane resistance might be questioned in view of Cole & Curtis's (1941) demonstration of the rectifying properties of the surface membrane. But any rectifier behaves as a linear element if it is examined with a sufficiently weak current. And we shall show later that the measuring currents used were probably small enough to keep the membrane in a linear part of its characteristic.

Some error must have been introduced by assuming that the membrane capacity behaved like a pure dielectric. The magnitude of the error cannot be estimated in any simple way, but it is not likely to have been very large. For a.c. measurements give a value of 76° for the phase angle of the dielectric of the membrane in the squid axon (Curtis & Cole 1938). This suggests that the membrane capacity would be reduced by 30 % when the frequency was increased tenfold. Most of the records dealt with here could be reproduced fairly accurately by a Fourier synthesis containing a tenfold range of frequencies and so would not have been greatly affected by imperfections in the membrane capacity.

METHOD

Material

Single-nerve fibres with a diameter of $60\text{--}80\mu$ were obtained from the walking legs of the common lobster (*Homarus vulgaris*). Live lobsters were bought from a fishmonger and kept in an aquarium filled with circulating sea water. The animals were in poor condition when first obtained, but they recovered after a few hours in the aquarium and were able to live there for several weeks. Axons were obtained from the first two pairs of walking legs which are chelate and appear to be better supplied with large fibres than the last two which have no terminal claw. The nerve was dissected from the meropodite and teased apart in a Petri dish of sea water. *Homarus* nerve contains much connective tissue, and separation of a single fibre proved to be a more laborious process than in a *Carcinus* preparation. More time had to be spent in cutting away connective tissue, and no attempt could be made to pull fibres apart until they had been freed from the strands of connective tissue which bound them together. All loose material was removed from the isolated axon whose length varied from 25 to 40 mm. Fibres with branches were never employed.

The method of isolating *Carcinus* axons was similar to that employed in earlier work (Hodgkin 1938) and need not be described again.

Apparatus

A general plan of the equipment used is shown in figure 3. The axon was kept in paraffin oil and was gripped at each end by the tips of insulated forceps (*AA'*). It was held in a horizontal position and could be observed from above by means of a binocular microscope. The axon rested on the wick electrodes *B*, *D*, and made contact with the tip of electrode *C*. Electrodes *B* and *D* made contact over a length of about 250μ , and electrode *C* over approximately 100μ . These three electrodes consisted of small glass tubes containing sea water and silver wires which had been coated electrolytically with chloride. One end of the glass tube was sealed with wax; the other was drawn out into a coarse capillary and plugged with agar sea water. Connexion to the nerve was made through fine agar wicks which projected for about 5 mm. beyond the tip of the glass capillary. The wicks were built by allowing agar sea water to solidify around a fine silk thread. Silver chloride electrodes were sufficiently non-polarizable, since a $5M\Omega$ resistance in series with the electrodes ensured that the current was entirely unaffected by residual electrode polarization. Electrode *E* did not need to be non-

polarizable, since it was used only for recording transient pulses with an amplifier of high input impedance. This electrode consisted of a fine glass tube into which a platinum wire was sealed; one end of the tube was drawn out into a fine glass capillary, ground square and the whole filled with sea water. The diameter of the tip was about 50μ and the region of contact with the nerve fibre of the same order of magnitude.

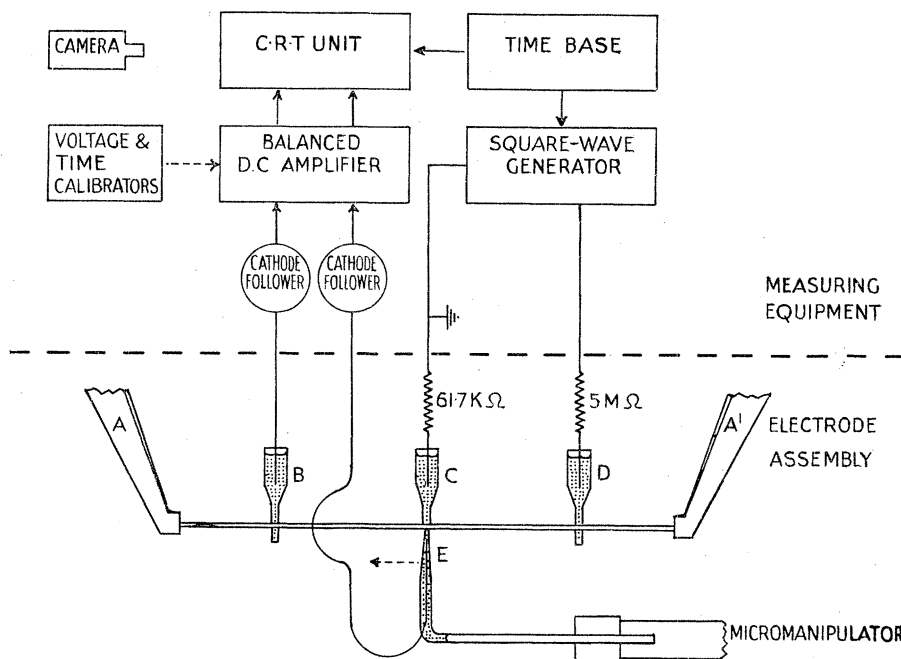

FIGURE 3. General plan of equipment. For letter references, see text.

Electrode *E* was held in a micromanipulator carriage and could be moved along the nerve fibre by turning one of the vernier controls on the manipulator. The electrode slid smoothly along the fibre provided that all loose connective tissue had been removed and that the direction of movement was parallel to the axis of the fibre. The position of the electrode was determined by a scale on the manipulator which was calibrated to read in fractions of a millimetre. This method of measurement was checked periodically by observing the motion of the electrode under the binocular microscope. The movement of the electrode was found to be the same as that given by the scale on the screw adjustment. Back-lash could be taken as zero, since it was less than 10 micra.

All electrical measurements were made by applying a rectangular pulse of current to the axon and recording the resulting potential changes with an amplifier and oscillograph. The rectangular pulse was generated by means of an arrangement of thyratrons (R.C.A. 885) and a multivibrator of the type described by Schmitt (1938). The wave form of the rectangular pulses was tested by connecting the pulse output to the plates of a cathode-ray tube. This showed that the deflexion was 90 % complete in less than $10\mu\text{sec}$. The pulse could be synchronized with the sweep circuit and its duration varied between 10 and $10^8\mu\text{sec}$. A low-resistance attenuator was used for varying the magnitude of the pulse applied to the nerve. One terminal of the pulse generator was connected to earth; the other became positive for the duration of the pulse. The positive-going terminal was connected to electrode *D* through $5\text{M}\Omega$ and the other terminal (earth) to electrode *C* through a monitoring resistance of $61,700\Omega$. The 5-megohm resistance ensured that a constant current was passed through the nerve, while the monitoring resistance was used to measure the current through the nerve fibre. The pulses of current were repeated at a rate of about one a second.

Electrical changes were recorded with a balanced d.c. amplifier designed by Dr Rawdon Smith of the Psychological Laboratory, Cambridge. This consisted of three pairs of pentodes with separate anode loads and common cathode resistances. The line voltages were arranged so that the anode of one stage could be connected to the grid of the next. In this way the undesirable resistance chains usually associated with d.c. amplifiers were avoided. Occasional checks showed that the differential action of the amplifier was better than one part in five hundred (i.e. when both inputs were raised 1 V above earth the oscillograph deflexion was equivalent to less than 2 mV difference between inputs). Initial checks with a signal generator indicated that the response of the amplifier was substantially flat between 0 and 50 kcyc./sec. In order to increase the input impedance the recording leads were connected to the grids of two cathode followers which were placed at a distance of 15 cm. from the preparation. Calibrations of the input stage and the whole amplifier were made by applying the rectangular pulse to the grids of the input stage through a resistance of the same magnitude as that involved in recording from the nerve. This test showed that the deflexion produced was 90 % complete in about $30 \mu\text{sec.}$, and the system was therefore sufficiently rapid for the investigation of phenomena lasting several milliseconds. The d.c. input impedance was greater than $10^{10} \Omega$ and the grid current less than 10^{-10} amp.

The time base was calibrated by applying the output from a 500 cyc./sec. oscillator to the amplifier. Voltage calibrations were made by photographing the series of oscillograph lines produced by varying the position of a decade resistance attenuator. In this way a calibration grid was obtained and could be compared with the experimental results. In general the experimental records fell in a region which was linear to within 2 % and so could be analysed without correction. Corrections had occasionally to be made but did not materially affect the results, since the amount of instrumental distortion rarely exceeded 5 %. All photographic records were taken on film and were traced on to graph paper after they had been enlarged about ten times.

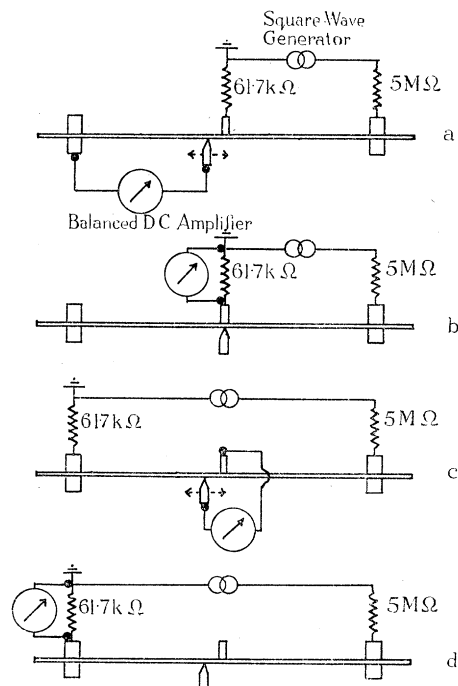

FIGURE 4. Arrangement of leads and electrodes employed in a quantitative experiment. *a*, system used for determining λ and τ_m ; *b*, system used in conjunction with *a* for determining y ; *c*, *d*, system used for determining m .

A typical experiment

The sequence of events in a quantitative experiment must now be described. The isolated axon was mounted on the electrode system and raised into a layer of aerated mineral oil which floated on the surface of the sea water. The recording electrode was brought into contact with the axon and a preliminary test made to ensure that the action potential was propagated normally throughout the whole fibre. The strength of current was reduced until it was below half-threshold and the potential response observed visually on the C.R.T. The duration of the rectangular wave was adjusted until it was sufficient to allow the membrane voltage to reach its equilibrium value. A test was made to ensure that the recording electrode slid smoothly along the axon. A series of photographic records of the extrapolar potential was then obtained with the arrangement of electrodes shown in figure 4*a*; in general these were similar to those in figure 6. One set of records was made with the movable electrode receding from the cathode and another with it approaching. There was sometimes a difference of 5 or 10 % between the two sets of records, but as a rule they agreed closely with one another. The current through the axon was determined with the arrangement of electrodes shown in figure 4*b* and a typical record is given in figure 6. This observation also provided a routine check of the squareness of the current wave form through the nerve fibre. The next operation was to determine the voltage gradient in the mid-interpolar stretch using the arrangement of figure 4*c*. The recording electrode was moved along the axon and a series of records similar to those in figure 9*a* obtained. The current through the axon was again determined; the arrangement of leads being that of figure 4*d* and a typical record that of figure 9*b*. At the end of each experiment the fibre diameter was measured in the following way. The axon was lowered into sea water and transferred to a hollow-ground slide; it was then examined with a microscope using a $\frac{1}{8}$ in. objective and an eyepiece micrometer. Some variation in diameter was always encountered, but this rarely exceeded 5 %.

RESULTS

*Preliminary experiments**Local response and passive spread of potential*

In attempting to measure the membrane resistance it is important to ensure that measurements are made in the linear part of the nerve characteristic, and that the results are not complicated by the non-linear phenomena of local response and rectification. From this point of view currents which are much weaker than threshold should be employed. On the other hand, as the current is reduced the amplification must be increased and errors from other sources increase. This fact will be appreciated by anyone who has worked with a single-fibre preparation and a high-gain d.c. amplifier. It is sufficient to mention the difficulties which arise from stray interference, shock artifact and the irregular drifts in voltage which occur in the amplifier and in the nerve and electrode system. Preliminary tests indicated that a reasonable compromise would be to use currents with a strength of 0.4–0.5 threshold. An absolute value for the resulting current density through the membrane cannot be given, since it varied with the excitability and membrane resistance of individual axons. But a rough estimate is that the current density under the electrode was of the order of $5 \mu\text{A cm.}^{-2}$. The total current through the axon was roughly $0.1 \mu\text{A}$. The absence of any significant response in the region below half-threshold is illustrated by an experiment with a *Carcinus* fibre (figure 5). Here the behaviour of the axon is shown for different strengths of applied current. Anodic or weak cathodic currents appear to affect only the passive charging process;

for all the curves have the same shape and their amplitude is roughly proportional to the applied current. And the shape of the curves is of a type which is to be expected from a process involving passive charge and discharge of the membrane capacity. The picture changed completely when the applied current approached threshold. At 0.9 threshold the cathodic potential showed a fast creep, and at 1.0 the curves turned upwards as if to give rise to a propagated impulse. But a true

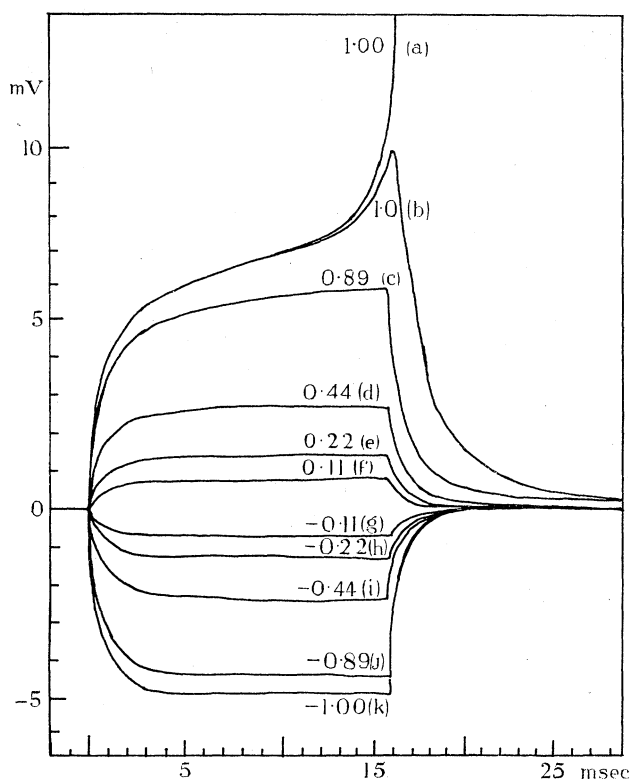

FIGURE 5. Response of *Carcinus* axon to rectangular waves of current of different intensity; recorded at a polarizing electrode of width about 200μ . The numbers on each record give the strength of current relative to threshold. Depolarization of the nerve is shown as positive.

action potential did not result in every case. Owing to the spontaneous play in excitability, a stimulus does not invariably evoke an impulse until its strength is slightly greater than threshold. In fact, a threshold shock is normally defined as one which produces impulses on 50 % of occasions. Record *b* shows what happens when a threshold shock failed to evoke an impulse. The potential turned upwards as if to give rise to a spike, but it failed to reach a critical level and died out as a localized wave. Inflected local responses of this kind only occurred when the current was nearly threshold but their onset was completely gradual. Thus all transitions between records *b* and *c* could be obtained by careful adjustment of the strength of current.

The striking form of local response illustrated by this experiment was observed on a large number of occasions and will be described in greater detail later. For the moment our chief concern is that it did not occur when the current was less than half-threshold.

Measurement of the curves in figure 5 indicated that there were small deviations from linearity in the region below half-threshold. At present there is no evidence to show whether these deviations were reproducible, and they may well have been instrumental in origin.

The effect of long pulses of current

The observations of Cole & Hodgkin (1939) on membrane resistance were made with currents lasting several seconds, while the duration of the currents used in the present work was of the order of 20 msec. It is legitimate to ask whether the two methods of measurement give comparable results. One or two experiments with long pulses were made in order to answer this question. The point at issue is whether the steady potential which is established in a few milliseconds is really constant, or whether there may not be a creep of potential which is too slow to register on the time scale used. Records showing the effect of pulses lasting 300 msec. were therefore made on a slow time base. The result was unequivocal, since the potential attained its maximum in a few milliseconds and then remained constant for the duration of the pulse.

Experiments with dead nerve fibres

Measurements of the extrapolar potential are liable to be complicated by errors and artifacts of various kinds (cf. Bogue & Rosenberg 1934). A number of control experiments were therefore made in order to ensure that the potential recorded in the extrapolar region was entirely due to accumulation of charge at the nerve membrane. In general, we found that the spread of potential in the extrapolar region was reduced progressively as the fibre lost its physiological activity, and that it finally fell to a low value when the fibre became inexcitable. A very striking demonstration of this general type of behaviour can be obtained by allowing the axon to come into contact with a solution of chloroform. Figure 6 illustrates an experiment of this kind. Records *b-g* show the spread of potential in the extrapolar region of a normal axon, and demonstrate the passive accumulation of charge at the surface membrane. The fibre was then dipped into sea water which had been shaken with chloroform. It was left in this solution for 1 or 2 min. and raised into oil. The result was extremely striking; for the potential change at the cathode was reduced to one-twentieth of its former value and was abolished at all other points. Records *a* and *A* are an index of the current through the axon, which was unchanged by the chloroform treatment. This experiment illustrates the delicate nature of the surface membrane and provides a convincing demonstration of the virtual absence of artifacts. The small potential which is recorded at the cathode in *B* may be attributed either to a residual membrane resistance or to the finite thickness of the nerve fibre. Close examination of the original records revealed a rapid spike which occurred at the beginning and end of the square wave, but was too faint for

reproduction. This persisted after chloroform treatment and must be regarded as an artifact caused by capacitive coupling between the polarizing and recording leads. The spike was ignored in analysing the records, but served a useful purpose in defining precisely the beginning and end of the applied current.

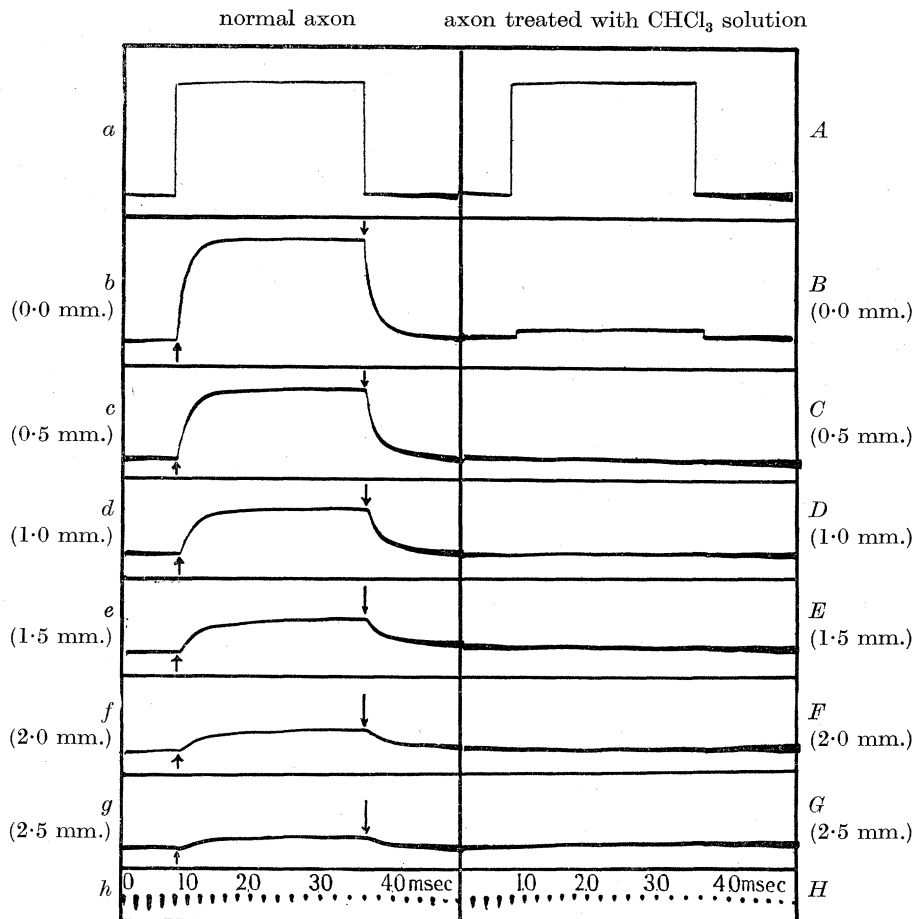

FIGURE 6. Effect of chloroform solution on spread of membrane potential in *Homarus* axon. *a*, *A*, current through normal and chloroform treated axon, measured as voltage across $61,700\Omega$ resistance in series with axon; *b*–*g*, potential recorded in extrapolar region of normal axon; the distance from the cathode is shown by the figures in brackets; *B*–*G*, potentials recorded in the same way after application of chloroform solution; *h*, *H*, 500 cyc./sec. time calibration. The vertical arrows indicate the beginning and end of the square wave of current and were marked from a capacitive artifact which appeared on the original records. Records *a* to *c* have been retouched. The amplification was the same in all records and the amplitude of the wave in *b* was approximately 4.5 mV. Records taken from experiment 13.

The measurement of λ

Equation (6.2) shows that there should be an exponential relation between the steady potential in the extrapolar region and the distance from the cathode. Hence a straight line with slope $(\log_{10} e)/\lambda$ should result when the \log_{10} of the

potential is plotted against distance. This method was used in all the experiments and is illustrated by figure 7. In drawing a straight line through the experimental points, more weight was placed on observations near the cathode, since the percentage error increased as the recorded voltage decreased. Figure 8 proves that this procedure gave satisfactory results. Here the results of all the experiments are plotted on a linear scale: the ordinate giving the potential as a fraction of the potential at the cathode and the abscissa giving distance as a fraction of the space constant. If equation (6.2) were obeyed perfectly all the points should fall on an exponential curve which is drawn as a solid line. In practice there are deviations, but in no case are they at all serious. Hence this set of observations demonstrates the validity of the theory and of the method of measurement employed.

Table 2 shows that the average value for λ was 1.6 mm., but that its magnitude varied considerably in individual experiments. As will appear later the variations are primarily due to differences in the membrane resistance, and the scatter in the results reflects the variable nature of this quantity.

TABLE 2. ELECTRICAL CONSTANTS IN TEN AXONS FROM *HOMARUS VULGARIS*

experi- ment number	axon number	dia- meter μ	λ mm.	y $\Omega \times 10^3$	m $M\Omega \text{ cm.}^{-1}$	τ_m msec.	r_2/r_1	R_2 $\Omega \text{ cm.}$	R_4 $\Omega \text{ cm.}^2$	C_M $\mu\text{F cm.}^{-2}$
1	1	65	1.80	78	0.72	1.6	0.82	43.6	1910	0.83
2	2	80	1.07	49	0.80	1.8	0.87	75.2	927	1.94
3	3	62	1.90	77	0.98	2.4	1.21	65.4	2784	0.87
4	4	76	1.40	80	0.88	5.4	0.76	70.6	1655	3.24
5	5	76	1.82	134	0.86	3.7	0.59	63.0	2955	1.25
6	6	73	2.95	103	0.90	4.0	1.3	83.6	7330	0.55
	7	6	73	2.62	114	0.73	3.3	0.84	55.9	4590
8	6	73	1.95	55	0.76	1.3	1.35	74.6	2720	0.46
	9	7	87	1.31	54	0.59	0.76	61.2	1150	0.66
10	8	78	1.29	137	0.74	1.9	0.35	48.1	1590	1.23
	11	8	0.81	112	0.71	0.91	0.26	43.2	706	1.29
12	9	73	0.92	40	0.72	0.89	0.84	55.6	564	1.58
13	10	80	1.15	55	0.66	2.5	0.69	56.6	905	2.73
average value		75	1.61	81	0.83	2.3	0.81	60.5	2290	1.33

Square brackets indicate that successive measurements were made on the same nerve fibre; curved brackets that they were made on the same stretch of the same fibre. Temperature: 15–20° C. Strength of current: 0.4–0.5 threshold. The values given for τ_m are the mean of four measurements.

The measurement of y

The constant y has the dimensions of a resistance and is given by the ratio of the steady voltage at the cathode to the applied current (see equation (6.1)). The method of measurement is clarified by referring to figure 6. Here b gives the voltage at the cathode and a the voltage across $61,700 \Omega$. Hence $y = 61,700 \times b/a \Omega$, where b/a is the ratio of the observed voltages. In this case y was $55,400 \Omega$, which was rather smaller than that usually obtained (see table 2).

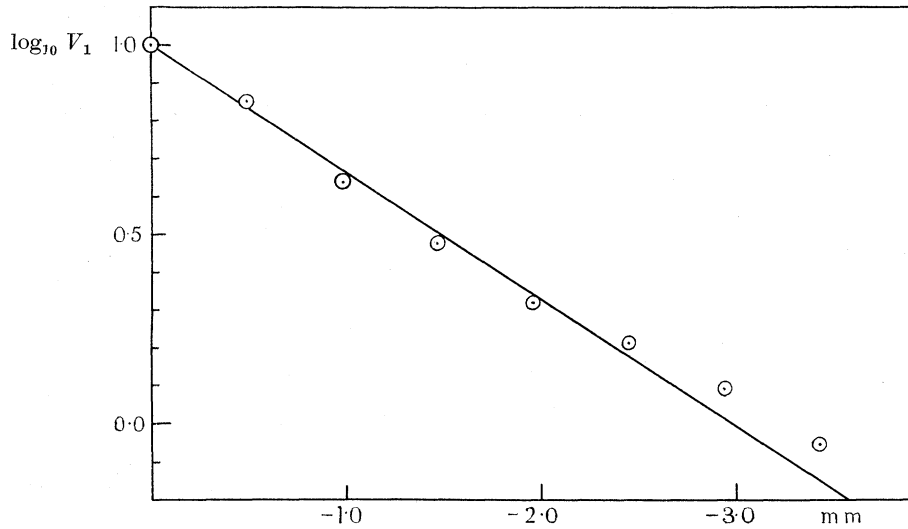

FIGURE 7. Equilibrium distribution of extrapolar potential. Ordinate: \log_{10} potential. Abscissa: distance of recording electrode from cathode in mm. The distance is shown as negative in order to conform to the convention used in the theoretical section.

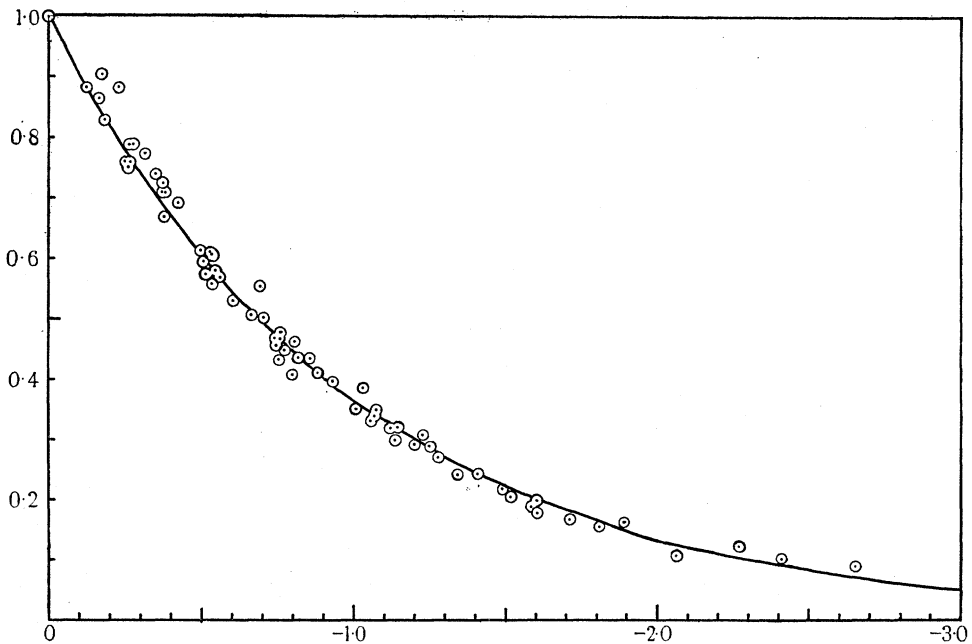

FIGURE 8. Equilibrium distribution of extrapolar potential in thirteen experiments. Ordinate: potential as a fraction of the potential at the cathode. Abscissa: distance as a fraction of the measured space constant λ . The solid line is drawn according to equation (6.2).

The measurement of m

m has been defined as the parallel resistance of core and external fluid. It was determined by measuring the voltage gradient midway between two distant electrodes and dividing the gradient by the current through the nerve. Typical records for determining m are given in figure 9. According to theory all these records should be perfectly rectangular, since the membrane impedance is not involved in the mid-interpolar region. The records actually show a slight creep, which can be explained in various ways. It might have been due to some capacitative property of the axoplasm or to irregularities in the diameter of the axis cylinder; or it could be attributed to the fact that the electrodes were not really an infinite distance apart as assumed in the theory. Whatever its explanation, the effect is not of present importance, since it makes little difference whether the maximum or the sudden rise is used for analysis. On the whole it seemed best to measure the sudden rise, since any effects introduced by the membrane were avoided by this procedure. The deflexion observed at any point could be expressed as a resistance by comparing it with the effect produced by the monitoring resistance. It was therefore possible to plot resistance against electrode separation as has been done in figure 10, which illustrates three typical experiments. The observed points fall very close to straight lines as they should according to theory. A direct measurement of m is given by the slope of the best straight line through the experimental points. The random nature of the errors involved seemed to justify a statistical treatment and m was therefore determined by the standard 'least square' formula.

The measurement of τ_m

The spatial and temporal distribution of the extrapolar potential are determined by the two constants λ and τ_m . λ has already been obtained so that τ_m can be determined by comparing experimental and theoretical curves. But first it must be established that the experimental records agree with the rather complicated equations of cable theory. Practice and theory are usually related by comparing experimental points with a theoretical curve. Here the situation is more complicated, since the experimental observations consist of a family of curves instead of a single set of points. In other words a three-dimensional surface has been found and must be compared with a theoretical surface. This imposes a much more drastic test on the theoretical equations, since only one parameter, τ_m , can be varied to make a number of curves coincide. In such a case it would be too much to hope for complete agreement at every point on the nerve. Nevertheless, agreement between theory and practice is reasonably good, as may be seen from figure 11. Here tracings of the voltage-time records at different distances are compared with the corresponding theoretical curves for those distances. Only a finite number of theoretical curves was computed and it was therefore impossible to use a theoretical curve which corresponded exactly with the experimental one. Thus C is the experimental curve for $x/\lambda = 0.38$ and d the theoretical curve for

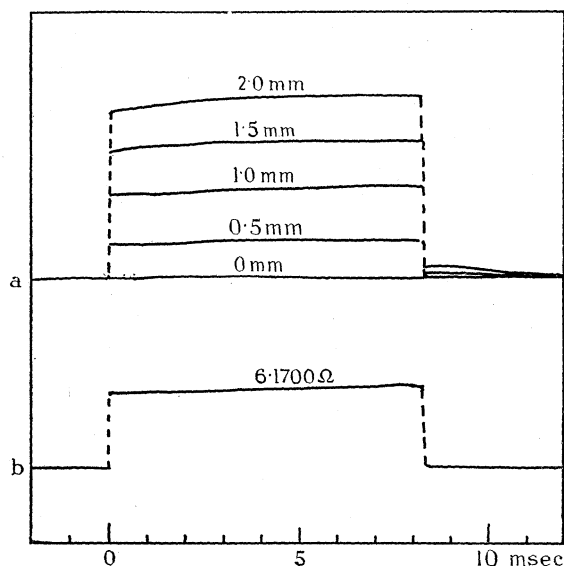

FIGURE 9. *a*, voltage gradient in mid-interpolar region. Records obtained with arrangement of figure 4*c* and with measuring electrodes separated by distances of 0–2.0 mm. *b*, voltage across $61,700\Omega$ using the same strength of current as that in *a*. Electrode arrangement as in figure 4*d*.

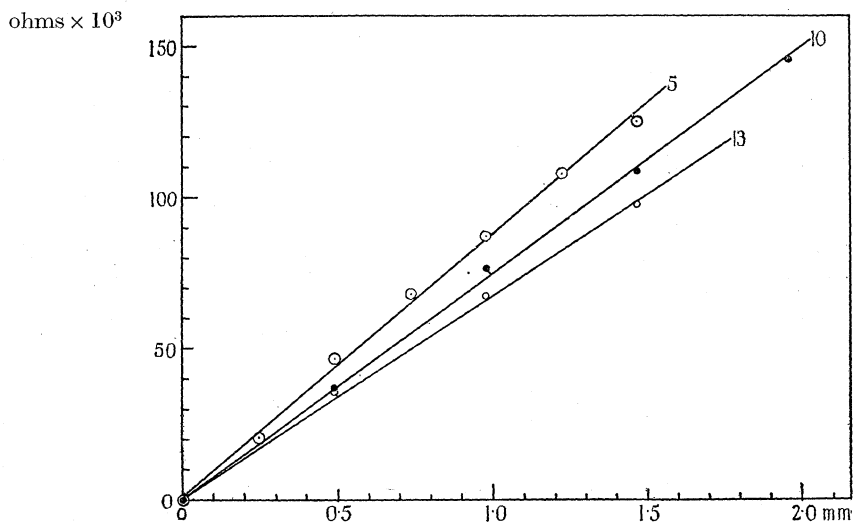

FIGURE 10. Resistance length relation in the mid-interpolar region. Ordinate: resistance, measured from records of the type shown in figure 9. Abscissa: distance between recording leads. The numbers on the straight lines refer to the experiments in table 2. The current was led into the nerve through electrodes about 16 mm. apart.

$x/\lambda = 0.4$. But the small differences introduced by this method of plotting do not materially alter the general picture of close agreement between theory and practice. Nor do they obscure the fact that there are certain real differences between the two sets of curves. Thus the record at the cathode rises more slowly than the corresponding theoretical curve, while the descending curves agree closely at the cathode but diverge at larger distances.

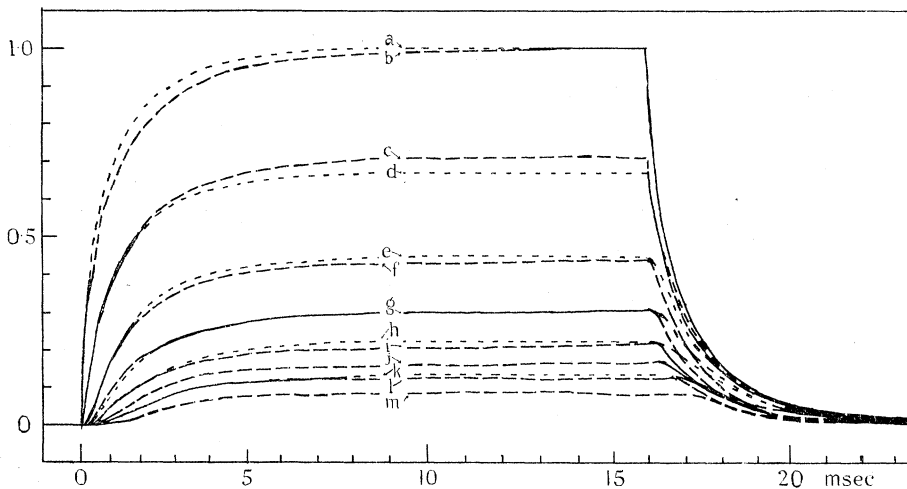

FIGURE 11. Experimental and theoretical curves showing rise and fall of extrapolar potential at different distances from cathode. Experiment 10 (table 2); $\lambda = 1.29$ mm. Abscissa: time in msec. Ordinate: potential expressed as a fraction of the equilibrium potential at the cathode.

- | | |
|--|--|
| a. Theoretical curve with $-x/\lambda = 0.0$ | h. Theoretical curve with $-x/\lambda = 1.5$ |
| b. Experimental curve with $-x/\lambda = 0.0$ | i. Experimental curve with $-x/\lambda = 1.52$ |
| c. Experimental curve with $-x/\lambda = 0.38$ | j. Experimental curve with $-x/\lambda = 1.89$ |
| d. Theoretical curve with $-x/\lambda = 0.4$ | k. Theoretical curve with $-x/\lambda = 2.0$ |
| e. Theoretical curve with $-x/\lambda = 0.8$ | l. Experimental curve with $-x/\lambda = 2.27$ |
| f. Experimental curve with $-x/\lambda = 0.76$ | m. Experimental curve with $-x/\lambda = 2.65$ |
| g. Experimental curve with $-x/\lambda = 1.14$ | |
| Theoretical curve with $-x/\lambda = 1.2$ | |

Theoretical curves drawn according to equations (6.0) and (6.4) with τ_m taken as 2.10 msec. Arrangement of electrodes as in figure 4a. Rectangular pulse with strength about 40 % threshold. The abscissa is not quite linear and the theoretical curves have been plotted according to the actual scale and not to a hypothetical linear scale; time calibrations derived from 500 cyc./sec. oscillator. A continuous line indicates that theoretical and experimental curves coincide.

The general coincidence between theory and experiment illustrated by figure 11 was only obtained because the theoretical curves were plotted with the correct time constant which in this case happened to be 2.10 msec. This value was obtained by a laborious process of trial and error which was too cumbersome for use in every experiment. It was therefore necessary to find a swifter method of computation. One possibility is to make use of the equations for total charge. This method was of little general use, but will be described briefly because it is of considerable

theoretical interest. Equations (5.2) and (5.3) show that the total charge obeys simple exponential laws. It follows immediately that the total extrapolar charge, which is proportional to $\int_{-\infty}^0 V_1 dx$, must also obey exponential charging laws. This quantity can be obtained by graphical integration of the potential in the extrapolar region and may then be plotted against time. The result of such an analysis is given in figure 12. Here the theoretical curve for the rise of a charge is drawn with a time constant of 2.02 msec. and for the fall with a time constant of 1.65 msec. The charging process obviously agrees closely with theory, but there is a definite deviation in the process of discharge. Further, the time constant for the charging process agrees with that found previously (2.10 msec.), whereas the discharge constant is appreciably smaller. The reason for these discrepancies is not clear, but they may arise from an apparently trivial circumstance. During the charging process the potential is relatively large and occupies a small area, whereas the converse situation holds during the period of discharge (see figures 2 *a, b*). This means that graphical integration is much less susceptible to cumulative errors in the former case than it is in the latter. The discharge curve may therefore be a less reliable index of the behaviour of the nerve than the corresponding charging curve. Whatever the explanation, this method will not be pursued further, since it proved too laborious for use in more than one experiment.

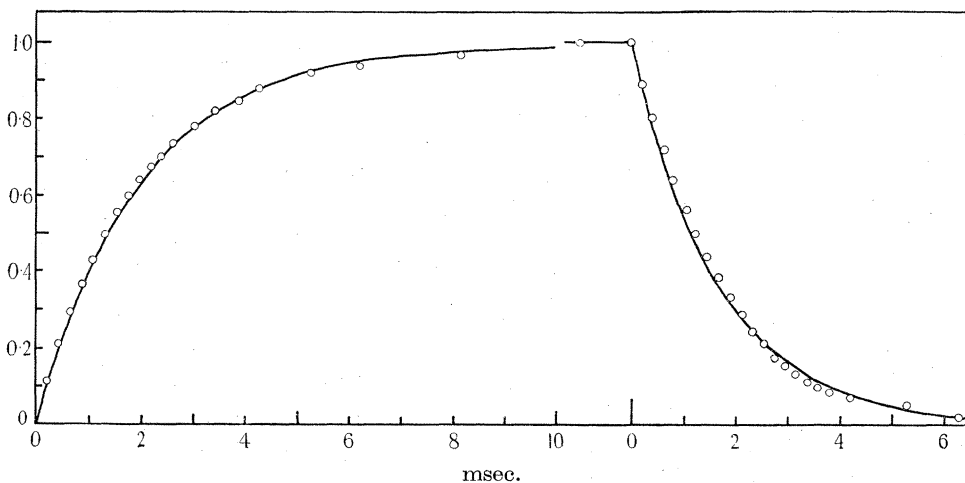

FIGURE 12. Time course of total membrane charge in extrapolar region. Abseissa: time in msec. Ordinate: $\int_{-\infty}^0 V_1 dx$ in arbitrary units. The circles are experimental points computed by graphical integration of photographic records from experiment 10. The solid line is a plot of equations (5.2) and (5.3) with $\tau_m = 2.02$ and 1.65 msec. for the rise and fall, respectively.

A simple method of measuring the membrane time constant is to ignore all observations except those at the cathode and find the time constant by comparing a single theoretical curve with the correct equation ((6.3) or (6.5)). This can be

done for both charging and discharging processes and has the advantage of simplicity. But it suffers from two serious disadvantages. In the first place it ignores a great deal of valuable information, and in the second it is liable to magnify the errors which arise from the finite width of the electrode. The general effect of electrode width is to lengthen the apparent time constant; for the effective cathode occurs on the interpolar side of the electrode and the effective recording point on the extrapolar side. With a cathode of width $\lambda/10$ the apparent time constant should be 10 % larger than the true time constant. But no worth-while correction can be made, since the exact current distribution at the electrode is unknown. Time constants measured by this method should therefore be regarded as only approximately correct.

Another method of measuring the time constant depends upon a remarkable property of equations (6.0) and (6.4). If the time to reach half-maximum is plotted against distance, a curve is obtained which is very nearly a straight line with a slope of $2\lambda/\tau_m$. An alternative statement of this result is that the half-value potential propagates at a constant velocity of $2\lambda/\tau_m$.* Since λ is known, τ_m can be obtained by measuring the velocity of propagation from the experimental records.

Seven methods of measuring τ_m from the experimental data have now been described:

- (1) Trial and error to find best overall fit of experimental curves.
- (2) Rate of rise of total charge in extrapolar region.
- (3) Rate of fall of total charge in extrapolar region.
- (4) Rate of rise of potential at cathode.
- (5) Rate of fall of potential at cathode.
- (6) Propagation velocity of half-value potential following make of current.
- (7) Propagation velocity of half-value potential following break of current.

All seven methods were applied to one experiment, with the following results:

method	apparent time constant (msec.)	method	apparent time constant (msec.)
1	2.10	5	2.10
2	2.02	6	1.63
3	1.65	7	1.40
4	2.67	average	1.93

The last four methods were applied as a routine procedure to all the experiments, with results which are shown in table 3. The agreement between different methods is often poor and the variations seem to be entirely random in nature. But there is little doubt as to the order of magnitude of the time constant, and it is this that is of interest at the moment.

* A footnote in Bogue & Rosenberg's (1934) paper suggests that this relation was known to Cremer.

TABLE 3. VALUES OF MEMBRANE TIME CONSTANT (τ_m) OBTAINED BY FOUR DIFFERENT METHODS

experiment number	τ_m in msec. determined by method				τ_m in msec. average
	4	5	6	7	
1	1.97	1.71	1.28	1.40	1.6
2	1.28	1.49	2.48	1.96	1.8
3	3.09	2.34	2.49	1.80	2.4
4	3.85	6.22	6.00	5.40	5.4
5	4.51	3.91	3.33	3.06	3.7
6	2.90	2.67	5.64	4.86	4.0
7	3.46	3.11	3.28	3.18	3.3
8	0.81	0.84	1.81	1.59	1.3
9	0.73	0.91	0.78	0.63	0.76
10	2.67	2.10	1.63	1.40	1.9
11	1.24	1.22	0.65	0.54	0.91
12	1.17	1.36	0.56	0.49	0.89
13	2.43	3.50	1.82	2.12	2.5
average	2.31	2.40	2.44	2.19	2.34

The relative magnitude of internal and external resistances

The ratio of the internal to external resistance per unit length (r_2/r_1) is important, because it allows us to estimate the absolute magnitude of potential changes at the nerve membrane. Equation (1.4) was derived without reference to the properties of the surface membrane, and it may therefore be applied to any region of nerve which does not form part of an external circuit. In general

$$\begin{aligned} & \text{(potential change at membrane)} \\ & = \text{(potential change recorded externally)} \times (1 + r_2/r_1). \end{aligned}$$

r_2/r_1 was obtained from the experimental results by equation (8.3) and calculated values are given in table 2. Action potentials were measured in five of these experiments, and the absolute magnitude of the electrical change at the surface membrane could therefore be estimated. The average value for the membrane action potential was found to be 110 mV and the extremes 135 and 87 mV. This result is in good agreement with the direct measurements which have been made with a micro-electrode in squid axons (Curtis & Cole 1942; Hodgkin & Huxley 1939).

The measurement of r_2/r_1 was subject to a small systematic error. In the theory it was assumed that the electrode was infinitesimal in width, whereas it actually had an effective width of 100–150 μ . The measured value for r_2/r_1 would therefore exceed the true value by an amount which we estimate roughly at 10 %.

The axoplasm resistivity (R_2)

The resistivity of the axoplasm can be computed by equation (8.0):

$$R_2 = \pi a^2 m (1 + m\lambda/2y).$$

It would be unwise to expect great accuracy or consistency in the calculated value of R_2 , since four separate measurements enter into its determination, and the final

result is subject to the errors which arise from the assumption of infinitesimal electrode width. A rough estimate of the total error in R_2 is that it amounts to $\pm 30\%$. Table 2 shows that the average value of R_2 was 60.5Ω cm. and the limits 43.2 and 83.6Ω cm. The average value of the axoplasm resistivity was, therefore, about three times as great as that of the surrounding sea water. This result is similar to those obtained for other cells. Measurements with transverse electrodes gave an average value of four times sea water for the resistivity of squid axoplasm (Cole & Curtis 1938), and observations with axial electrodes an average of 1.4 times sea water for the same material (Cole & Hodgkin 1939). Red and white blood corpuscles have a resistivity of twice plasma, frog's sartorius muscle one of about three times Ringer and various echinoderm eggs a resistivity of four to eleven times sea water (for references see Cole & Cole (1936) and Bozler & Cole (1935)).

The membrane resistance

The resistance \times unit area of the surface membrane is determined by equation (8.1):

$$R_4 = 2\pi a\lambda^2 m(2 + m\lambda/2y + 2y/m\lambda).$$

Table 2 shows that the ratio r_2/r_1 which is equal to the factor $m\lambda/2y$ usually lies between $\frac{2}{3}$ and $\frac{3}{2}$. This means that a large error in $m\lambda/2y$ will have only a small effect on R_4 . Suppose, for example, that the true value of $m\lambda/2y$ is 1.0 and that it is measured as 1.5. In the first case the factor in brackets in (8.1) would be 4.0 and in the second 4.17; hence the error in R_4 would only be 4%. A similar line of argument shows that the measured value of R_4 will only be very slightly affected by the assumption of infinitesimal electrode width. The accuracy of the R_4 determination is, therefore, primarily controlled by the measurement of λ^2 , a and m . The errors in λ^2 are likely to be of the order of $\pm 30\%$, and almost certainly swamp the errors in a and m . A conservative estimate of the accuracy of the measurements in table 2 is that the values given for R_4 are correct to within 50%. The observed variation was much greater than this, and successive measurements on one axon showed that the membrane resistance declined progressively during the course of an experiment. Thus axons 6 and 8 had initial resistances of 7330 and 1590 Ω cm.², while their final resistances were 2720 and 706 Ω cm.². The variable properties of the surface membrane mean that an average or standard value cannot be given for its resistance. All that can be said is that axons with resistances varying from 600 to 7000 Ω cm.² are capable of conducting nervous impulses in a normal manner. It is equally impossible to estimate the value of the membrane resistance in the living animal. The natural membrane resistance is not likely to be less than that found *in vitro*, but it may be much higher since Blinks's (1930) work on *Valonia* indicates that the surface resistance falls when cells are handled.

The values for R_4 given in table 2 are considerably larger than those recorded in the squid axon. Cole & Hodgkin (1939) reported values ranging from 400 to 1100 Ω cm.² on the basis of resistance-length measurements with direct current, while Cole & Baker (1941*a*) obtained an upper limit of 200 Ω cm.² from measure-

ments with a.c. and transverse electrodes. On the other hand, Cole & Curtis (1941) give an average value of only $23\Omega \text{ cm.}^2$ from measurements with an internal electrode and d.c. pulses. Finally, Cole & Baker (1941*b*) calculated a value of $350\Omega \text{ cm.}^{-2}$ from the result of a.c. measurements with longitudinal electrodes and the assumption of a membrane capacity of $1.1\mu\text{F cm.}^2$. Cole (1941) appears to regard $300\Omega \text{ cm.}^2$ as a more or less average value. The low value of $23\Omega \text{ cm.}^2$ was attributed by Cole & Curtis (1941) to the poor physiological condition of impaled axons, but as they point out it may also have been due to the fact that two constants required in the analysis were assumed and not measured. In any case, there seems to be no doubt that the membrane resistance of 75μ lobster axons is several times larger than it is in 500μ squid axons. This difference may have some functional significance, since the rate of attaining ionic equilibrium tends to increase with surface-volume ratio, other things being equal. The membrane resistance would therefore need to decrease as the diameter increased if the cell economy demands a constant rate of approach to equilibrium.

The values of membrane resistance encountered in our work suggest that the permeability to ions must be rather low. Some idea of this may be gained by supposing that potassium ions alone can diffuse through the membrane and that permeability is studied by replacing the potassium in the external solution with a radioactive isotope. In this case it is fairly easy to show that approximately 30 min. would elapse before an 80μ fibre with a membrane resistance of $7000\Omega \text{ cm.}^2$ reached a state in which one-tenth of its internal potassium was replaced by the radioactive isotope. It would be interesting to see whether the rate of penetration of potassium is of this general order of magnitude.

Our values for the membrane resistance may be compared with those obtained by Dean, Curtis & Cole (1940) on artificial films containing lipid and protein molecules. These films were of the right electrical thickness, since their capacity was about $1\mu\text{F cm.}^{-2}$, but their electrical resistance was only $50\text{--}100\Omega \text{ cm.}^2$. It is too early to try to correlate this difference with chemical structure, but there is some hope that future work will show what sort of structure is needed to produce a membrane of high resistance.

The magnitude of the membrane capacity

The membrane capacity was determined by the relation

$$C_M = \tau_m/R_4.$$

Both τ_m and R_4 are subject to large errors, so that little confidence can be placed on the exact numerical values obtained for C_M . In fact, it is possible that the variation encountered in table 2 was entirely due to experimental error. But there can be little doubt that the membrane capacity was of the order of $0.5\text{--}2.0\mu\text{F cm.}^{-2}$. A value of this kind has been obtained in a wide variety of living cells; well-known examples are red blood cells $0.95\mu\text{F cm.}^{-2}$, yeast $0.60\mu\text{F cm.}^{-2}$, echinoderm eggs

0.87–3.1 $\mu\text{F cm.}^{-2}$, frog's sartorius muscle *c.* 1 $\mu\text{F cm.}^{-2}$, squid nerve 1.1 $\mu\text{F cm.}^{-2}$, and *Nitella* 0.94 $\mu\text{F cm.}^{-2}$ (for references and qualifications see Cole 1940).

All these results depend on the use of a.c., transverse electrodes and a theory based on Maxwell's application of Laplace's equation to a suspension of spheres. Our observations were made with pulses of d.c., longitudinal electrodes and a theory based on Kelvin's equations for the submarine cable. So it is pleasing to find even a broad agreement between the two sets of results.

The implications of the membrane capacity of 1 $\mu\text{F cm.}^{-2}$ are too well known to be repeated. All that need be said is that the result suggests the presence either of a very thin membrane, or of one with a large dielectric constant. If the dielectric constant were 3, the membrane thickness would be 27 \AA ; and if the thickness were 1 μ the dielectric constant would be 1100.

Possible membrane inductance

Cole & Baker (1941*b*) have presented experimental evidence which suggests that an inductive element is present in the surface membrane of the squid axon. No sign of inductive behaviour could be observed in the majority of our experiments. But the two sets of observations do not conflict in spite of the apparent contradiction. Cole & Baker's axons had a membrane resistance of about 300 $\Omega \text{ cm.}^2$, ours an average of 2300 $\Omega \text{ cm.}^2$. The effect of an inductive element would have been profoundly influenced by the value of the membrane resistance, since Cole & Baker's work indicates that the two elements are in series. To take a specific example: assume that the membrane has the equivalent circuit suggested by Cole & Baker, that the capacity is 1 μF , the inductance 0.2 H and the resistance 300 $\Omega \text{ cm.}^2$. When a rectangular current is applied to this circuit, the voltage response is oscillatory and the first overshoot is 75 % greater than the final steady value. The response is entirely different if the resistance is increased to 2500 $\Omega \text{ cm.}^2$. In this case the wave form is no longer oscillatory, it does not overshoot the steady value, and it differs from a simple exponential solution by less than 0.2 %. The absence of inductive or oscillatory behaviour therefore agrees with Cole & Baker's hypothesis, although it clearly cannot be used in evidence one way or the other. But some of the axons studied had low membrane resistances and should have shown signs of inductive behaviour, if Cole & Baker's picture is correct. This, in fact, is what happened. Figure 13*c* gives the response of an axon with a resistance of 700 $\Omega \text{ cm.}^2$ and shows that there is an overshoot of 5 %. There is no equation with which to compare this record, but a theory for total charge can be developed by the method used in deriving (5.1). The resulting expressions allow the membrane inductance (L) to be calculated from the overshoot and predict that the response will only be oscillatory when $L > R_4^2 C_m / 4$. Experiments 9, 11 and 12 (table 2) showed a small overshoot and gave an average value of 0.3 H for the membrane inductance. No overshoot was observed in the remaining experiments, and this is to be expected since the factor $R_4^2 C_m / 4$ always exceeded 0.4. Our results are therefore consistent with the existence of an inductive element of about 0.2 H cm.^2 .

But there is an entirely different way of explaining the experimental facts and this must now be considered. In figure 13 *a* and *b* the current had been increased until it was of just threshold strength, which means that it was strong enough to produce propagated spikes on 50 % of occasions. The propagated response is shown by *a* and the critical local response by *b*. It is arguable that the local response is of the same general nature as the spike, and that the discontinuity in nerve arises because the response to a superthreshold shock is large enough to involve the whole fibre by local circuit action, whereas the subthreshold response cannot spread beyond the cathodic region. It is also arguable that the small overshoot produced by the weak current is of the same general nature as the larger overshoot produced by the threshold current. And the similarity of the two lower curves in figure 13 suggests rather strongly that a common process is involved. According to this train of reasoning the overshoot seen in figure 13*c* is to be regarded as a vestige of the normal action potential. In this case it cannot be considered as an inductive effect. For the process underlying the action potential must involve energy liberation by the nerve, whereas a pure inductive overshoot would not. The two theories are therefore quite distinct, although no attempt can be made to decide between them until there are precise concepts to replace the general notions of inductance and energy liberation.

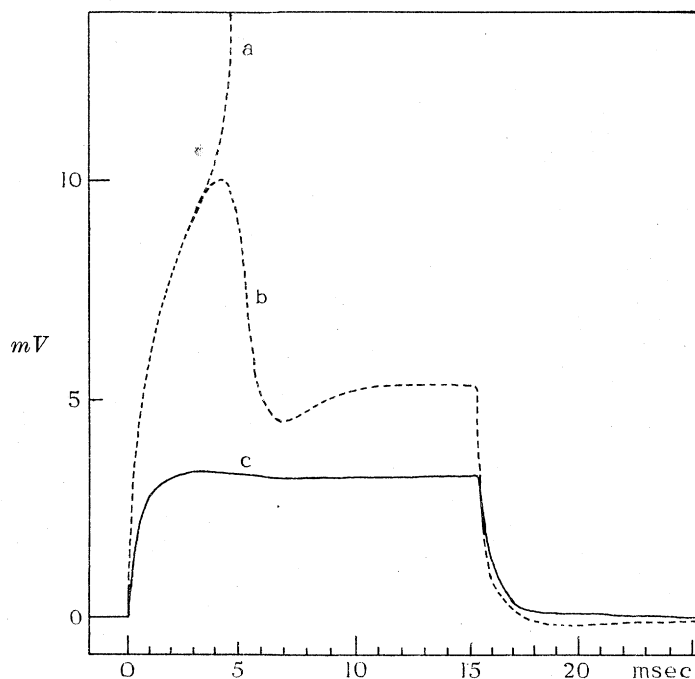

FIGURE 13. Potential recorded at cathode in axon with membrane resistance of $700\Omega \text{ cm.}^2$ (experiment 11). *a*, propagated response produced by current of strength 1.00; *b*, local response produced by current of strength 1.00; *c*, potential produced by current of strength 0.49. The absolute values given on the ordinate are approximate, but the scale is linear.

The idea of a membrane inductance is certainly useful, whatever its ultimate truth or falsehood. One application was found in the attempt to explain the difference between the action potential and the resting potential (Curtis & Cole 1942; Hodgkin & Huxley 1945). Another is illustrated by figure 14, which shows the effect of strong cathodic currents on a *Carcinus* axon. The records indicate that the wave form of the cathodic potential becomes increasingly oscillatory as

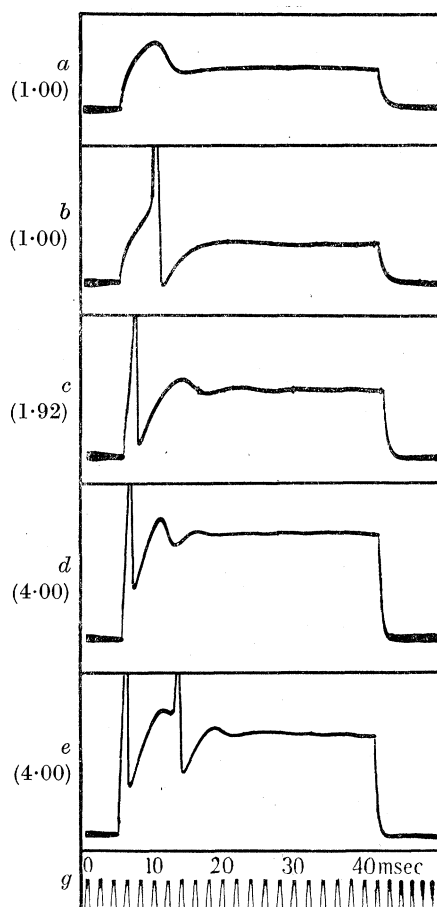

FIGURE 14. Effect of strong cathodic currents on *Carcinus* axon. Relative strength of current shown by bracketed figures. *g*, 500 cyc./sec. time calibration. Propagated spikes retouched.

Two points in figure 14 call for comment. After the oscillations have died out the membrane potential settles down to a steady value which is not proportional to the current but varies more slowly as the current is increased. This is an example of the membrane rectification described by Cole & Curtis (1941) in the squid axon.

In figure 14*e* a second spike arises from the second wave of potential, but a little after its crest. Hodgkin (1938) showed that a spike always started at a distance from the cathode when it arose later than the crest of the local response. Examination of the original records suggested that the same thing was occurring here, although no positive evidence for this conclusion was obtained.

the strength of current is increased. Similar results have been reported by Arvanitaki (1939) in *Sepia* and are to be expected from Cole & Baker's hypothesis. For the membrane resistance decreases progressively as the nerve is depolarized (Cole & Curtis 1941), and the response therefore becomes increasingly oscillatory as the current is raised. The frequency of the oscillations in figure 14 is consistent with an inductance of 0.3 H cm.^2 and a capacity of $2 \mu\text{F cm.}^{-2}$.

Observations on the local response

The most striking features of the local response were the inflexion and miniature spike which occurred when the duration of the rectangular wave was less than the utilization time. One example has already been described (figure 5), and a more general picture is given by figure 15 which shows the effect produced by threshold pulses of different duration. A large number of photographs were taken and with two exceptions only the responses which just succeed or just fail to propagate have been reproduced. The effect of a current longer than the utilization time is given by *c* and *C*. In this case the record shows first the passive charging of the nerve membrane and then a slow creep, which must be regarded as a local response, since it is absent from the anodic wave form (*a*). If the local activity succeeded in reaching a critical level it turned upwards and gave rise to a propagated action potential. When the critical level was not reached the response died out as a monophasic wave of low amplitude. The form of the propagating responses was not very different when the duration of the rectangular wave was less than the utilization time (*D* to *H*), but the responses which failed to propagate showed the characteristic inflexion and miniature spike (*d* to *h*). This type of response persisted as the duration of the current was reduced, but at very short times it changed to that characteristic of excitation by short shocks (cf. Hodgkin 1938). An example is given in *h* and *H*, but the details of the record cannot be appreciated on the slow time scale used. This set of records suggests that the condition for excitation by currents of different duration is that a critical potential must be reached; they also illustrate the reversibility of the process responsible for the action potential. One is accustomed to think that nothing can stop an impulse once the potential has begun to turn upwards into a spike. Our records indicate that the potential wave may fail to propagate, although it has shown the inflexion normally associated with a spike.

The records which have just been described were obtained from a *Carcinus* axon and may be regarded as typical of this preparation. *Homarus* fibres behaved in a similar manner, but the utilization time was considerably shorter and the rheobasic local response had a more conspicuous humped form. We obtained the impression that the long utilization time and flat local response were associated with a high membrane resistance, and that axons with a low resistance gave the short utilization time and humped local response characterized by figure 13.

In comparing our results with those obtained in whole nerve trunks it should be remembered that the amplitude of the subthreshold potentials was small compared

to the spike. Thus the propagated potential was ten times larger than the sub-threshold potential shown in figure 15. The effects we have described would therefore be difficult to observe in preparations giving spikes only $100\mu\text{V}$ in amplitude.

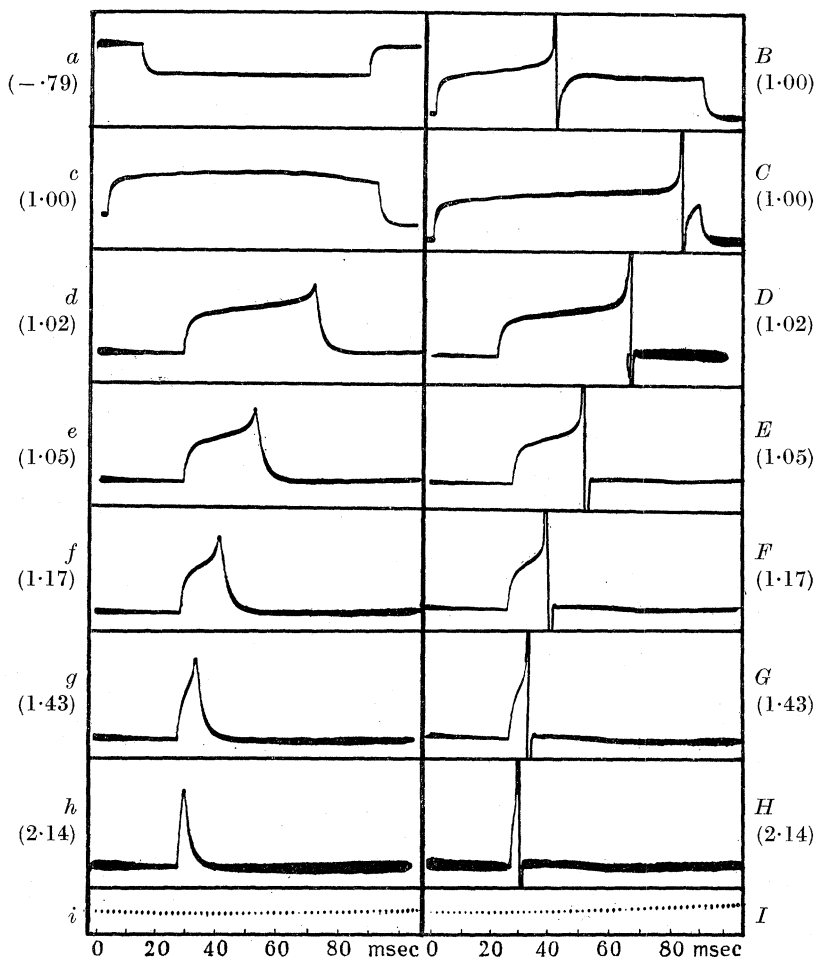

FIGURE 15. Effect of rectangular currents on *Carcinus* axon recorded at polarizing electrode. *a*, polarization produced by anodic current; *c-h*, local responses produced by threshold currents; *B-H*, propagated spikes (retouched) produced by threshold currents; *i*, *I*, 500 cyc./sec. time calibration. The strength of the current relative to the rheobase is indicated by the bracketed figures. The strength and duration of the current was identical in the pairs *c*, *C*, *d*, *D*, ..., *h*, *H*.

The change of membrane resistance during activity

A transient decrease of membrane resistance during activity has been proved by the well-known experiments of Cole & Curtis (1939). One result of this phenomenon is shown in figure 15*B*. Here the diphasic action potential arose before the end of the rectangular wave and lasted for about 2 msec. The membrane capacity should be discharged during the spike and must charge again when the resistance

returns to its normal value. The spike should therefore be followed by a charging process similar to that which occurred at the beginning of the rectangular wave. This effect is clearly shown by record *B* but is absent when the action potential arises at the end of the applied current (*D* to *H*). In this case the charge disappeared rapidly during the spike and did not reform, because the applied current was removed.

DISCUSSION

The implications of the resistance and capacity measurements have already been discussed. It remains to consider the bearing of our results on studies of electric excitation. The local responses observed in our experiments agree in a remarkable way with the instability described by one of us. Rushton (1932) studied the excitation process in medullated nerve by superimposing a short shock on a rectangular wave. A plot of excitability against time showed that the excitation process followed an inflected time course very similar to that observed in our records of local response. This is another example of the general similarity between the results of excitability studies on medullated nerves and the electrical records obtained in non-medullated nerve fibres. The phenomenon of latency and the excitability effects described by Rushton and by Katz (1937) all find an explanation in the electrical behaviour of isolated crustacean axons. The obvious conclusion is that similar electric effects exist in medullated axons, but that they are too small to be detected in studies of whole nerve trunks. This conclusion is not generally accepted and is likely to remain in dispute until satisfactory records can be obtained from an isolated medullated axon.

Hill (1936) and others have shown that many phenomena can be explained by supposing that the process of excitation is equivalent to the charging of a leaky condenser. This theory is useful in co-ordinating a wide range of observations, but extra assumptions have to be introduced to deal with the phenomena of accommodation, latency and the decay of excitability following a brief stimulus. Our results indicate that the processes underlying excitation are of great mathematical complexity. When the current is weak its spatial and temporal distribution is determined by the cumbersome equations of cable theory; when it is strong an immense complication is introduced by the non-linear effect of the local response. Hill's equations must therefore be regarded as largely empirical in nature. But there can be no doubt that certain facts seem to agree better with Hill's theory than with the cable equations. To take a specific example. It is universally agreed that the criterion for excitation by short shocks is that a fixed quantity of electricity must flow through the nerve. This follows at once from Hill's theory, but not from the equations of cable theory. For the condition which allows a short pulse to produce a constant potential at the cathode in a cable-like system is that a pulse of constant energy must flow through the electrodes. This difficulty and others of a similar kind can be resolved in the following way. The condition for excitation seems to be that the cathodic response must reach a potential at which it can propagate through the nerve by local circuit action. It is easy to suppose

that the criterion for propagation is related not to the membrane potential at the cathode but to the total membrane charge in the region of the electrode. In this case a constant quantity relation would be obtained and the behaviour of nerve would approximate to that of a leaky condenser in many respects. According to this view, Hill's 'local potential' is to be identified with the total charge in the electrode region and Hill's constant k with the membrane time constant. The true situation is obviously much more complicated, but this hypothesis provides a simple and convenient way of looking at the excitation process.

We wish to express our indebtedness to the Rockefeller Foundation for defraying the expenses associated with this work and to Professor Gray for allowing us to use the aquarium in the Zoological Laboratory.

REFERENCES

- Arvanitaki, A. 1939 *Arch. int. Physiol.* **49**, 209.
 Blinks, L. R. 1930 *J. Gen. Physiol.* **13**, 361.
 Blinks, L. R. 1937 *Trans. Faraday Soc.* **33**, 991.
 Bogue, J. G. & Rosenberg, H. 1934 *J. Physiol.* **82**, 353.
 Bozler, E. & Cole, K. S. 1935 *J. Cell. Comp. Physiol.* **6**, 229.
 Campbell, G. A. & Foster, R. M. 1931 *Fourier Integrals for practical applications*. Bell Telephone system Technical publications monograph, B. 584, 162.
 Cole, K. S. 1937 *Trans. Faraday Soc.* **33**, 966.
 Cole, K. S. 1940 *Cold. Spr. Harb. Symp. Quant. Biol.* **8**, 110.
 Cole, K. S. 1941 *J. Gen. Physiol.* **25**, 29.
 Cole, K. S. & Baker, R. F. 1941a *J. Gen. Physiol.* **24**, 535.
 Cole, K. S. & Baker, R. F. 1941b *J. Gen. Physiol.* **24**, 771.
 Cole, K. S. & Cole, R. H. 1936 *J. Gen. Physiol.* **19**, 609.
 Cole, K. S. & Curtis, H. J. 1938 *J. Gen. Physiol.* **22**, 37.
 Cole, K. S. & Curtis, H. J. 1939 *J. Gen. Physiol.* **22**, 649.
 Cole, K. S. & Curtis, H. J. 1941 *J. Gen. Physiol.* **24**, 551.
 Cole, K. S. & Guttman, R. M. 1942 *J. Gen. Physiol.* **25**, 765.
 Cole, K. S. & Hodgkin, A. L. 1939 *J. Gen. Physiol.* **22**, 671.
 Cremer, M. 1899 *Z. Biol.* **37**, 550.
 Curtis, H. J. & Cole, K. S. 1938 *J. Gen. Physiol.* **21**, 757.
 Curtis, H. J. & Cole, K. S. 1942 *J. Cell. Comp. Physiol.* **19**, 135.
 Dean, R. B. 1939 *Nature*, **144**, 32.
 Dean, R. B., Curtis, H. J. & Cole, K. S. 1940 *Science*, **91**, 50.
 Fricke, H. & Morse, S. 1925 *J. Gen. Physiol.* **9**, 153.
 Hermann, L. 1905 *Pflüg. Arch. ges. Physiol.* **109**, 95.
 Hill, A. V. 1936 *Proc. Roy. Soc. B*, **119**, 305.
 Höber, R. 1910 *Pflüg. Arch. ges. Physiol.* **133**, 237.
 Hodgkin, A. L. 1938 *Proc. Roy. Soc. B*, **126**, 87.
 Hodgkin, A. L. & Huxley, A. F. 1939 *Nature*, **144**, 710.
 Hodgkin, A. L. & Huxley, A. F. 1945 *J. Physiol.* **104**, 176.
 Jeffreys, H. 1931 *Operational methods in mathematical physics*, 2nd ed. Camb. Univ. Press.
 Katz, B. 1937 *Proc. Roy. Soc. B*, **124**, 244.
 Nernst, W. 1908 *Pflüg. Arch. ges. Physiol.* **122**, 275.
 Pumphrey, R. J., Schmitt, O. H. & Young, J. Z. 1940 *J. Physiol.* **98**, 47.
 Rushton, W. A. H. 1932 *J. Physiol.* **75**, 16P.
 Rushton, W. A. H. 1934 *J. Physiol.* **82**, 332.
 Schmitt, O. H. 1938 *J. Sci. Instrum.* **15**, 24.
 Warburg, E. 1899 *Ann. Phys., Lpz.*, **67**, 493.